

## Second Call

Press Notice for Publishing Newspaper

### NOTICE INVITING e-TENDER

The Executive Engineer, University Works Division, GGSIPU, Sector 16 C, Dwarka invites on behalf of Guru Gobind Singh Indraprastha University online item rate tenders for following work(s):-

Name of Work: A/A GGSIP University, Dwarka Campus, New Delhi

Sub Head: Setting up research lab

NIT No: 23/EE/UWD/Civil/2017-18 (Second call)

Estimated Cost : Rs. **14,32,194/-**, Time of completion : 45 days, EMD: Rs **28,644/-**

The tender forms and other details can be obtained from website <http://govtprocurement.delhi.gov.in>. Last date of submission of bids is **30/08/2017**. Date of pre bid meeting is 18/08/2017 at 11:00 AM.

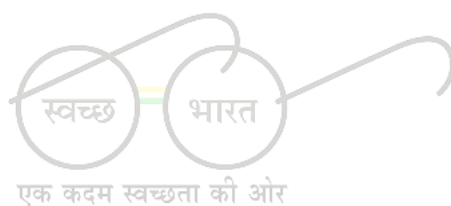

-sd/-  
**EE/UWD**

## Second Call

### Notice Inviting e-Tender

The Executive Engineer, University Works Division, on behalf of GGSIPU invites online Item rate bids from approved and eligible contractors as per eligibility criteria through e-procurement portal for the following work(s):

S. No.	NIT no.	Name of work & Location	Estimated cost put to bid	Earn est Money	Period of Completion	Pre-bid Meeting date & Time	Date of upload of tender on e-website	Last date & time of online submission of bid	Period during which EMD to be submitted	Time & date of opening of bid	Period during which eligibility documents shall be physically submitted
1	2	3	4	5	6	7	8	9	10	11	12
1	23/EE/UWD/Civil/2017-18 (Second call)	Name of work : A/A GGSIP University, Dwarka Campus, New Delhi Sub Head : Setting up research lab	Rs. 14,32,194/-	Rs. 28,644/-	45 days	18/08/2017 at 11:00 hrs	11/08/17	Upto 30/08/2017 15:00 hrs	Upto 30/08/2017 15:00 hrs	Upto 30/08/2017 15:30 hrs	By lowest bidder, within a week of opening of financial bid

1. The intending bidder must read the terms and conditions of CPWD-6 carefully. He should only submit his bid if he considers himself eligible and he is in possession of all the documents required.
2. The bidders who fulfill the following requirements shall be eligible to apply. Joint ventures are not accepted. The firm:
  - a) Should have satisfactorily completed three similar work each of value **Rs. 5,72,878/-** or two similar work each of value **Rs.8,59,316/-** or one similar work each of value **Rs.11,45,755/-** in last 7 years ending the last date of receipt of tenders. The completed value of works shall be enhanced @ 7% per annum to bring it to the current value upto last date of receipt of tenders. Similar work shall mean Supply Installation Testing and Commissioning of Modular Lab furniture including fumehood in Central Govt department, State Govt. department, Central/State PSU's Autonomous organization, Educational Institutions.  
**Note:** Copy of performance certificate duly issued by not below rank of Executive Engineer or equivalent to be submitted. Certificate of private institution should be supported by Form 26AS/TDS certificate. The certificate should clearly indicate scope of work, date of completion, completed value, name of work, agreement/order no., date of start etc. to verify eligibility wherever required, the certificate should be supported by schedule/final bill (certified) to establish similarity.
  - b) Should have valid GST registration or proof of having applied for obtaining the same.
  - c) Upto date VAT return of last quarter.

- d) Should have valid Pan no.  
e) Should furnish an affidavit for not subletting the work as under:-  
“I/We undertake and confirm that eligible similar work(s) has/have not been got

executed through another contractor on back to back basis. Further that, if such a violation comes to the notice of Department, then I/We shall be debarred for tendering in GGSIPU contracts in future forever. Also, if such a violation comes to the notice of Department before date start of work, the Engineer-in-Charge shall be free to forfeit the entire amount of earnest Money Deposit/Performance Guarantee.”

3. Information and Instruction for bidders posted on website shall form part of bid document.
4. The bid document consisting of plans, specifications, the schedule of quantities of various types of items to be executed and the set of terms and conditions of the contract to be complied with and other necessary documents can be seen and downloaded from website <http://govtprocurement.delhi.gov.in> or [www.ipu.ac.in](http://www.ipu.ac.in) free of cost.
5. But the bid can only be submitted after uploading the mandatory scanned documents as mentined at point 8 below:
6. On opening date, the contractor can login and see the bid opening process. After opening of bids he will receive the competitor bid sheets.
7. Contractor can upload documents in the form of PDF format.
8. Contractor must ensure to quote rate of each item. Therefore, if any cell is left blank and no rate is quoted by the bidder, rate of such item shall be treated as "0" (ZERO).

एक कदम स्वच्छता की ओर

**9. List of Documents to be scanned and uploaded within the period of bid submission:**

- I) Copy of EMD in favour of Registrar, GGSIPU.  
II) Copy of Certificates in support of eligibility  
III) Self attested copy of valid GST Registration Certificate or proof of having applied for obtaining the same  
IV) Self attested copy of VAT return filed up to last quarter.  
V) Self attested copy of PAN Card.  
VI) Copy of affidavit for not subletting

-sd/  
EE/UWD

## **INFORMATION AND INSTRUCTIONS FOR CONTRACTORS FOR e-TENDERING FORMING PART OF NIT AND TO BE POSTED ON WEBSITE**

1. Information and instructions for Contractors will form part of NIT.
2. The Bid Document as uploaded can be viewed and downloaded free of cost by anyone including intending bidder. But the bid can only be submitted after uploading the mandatory scanned documents.
3. After submission of the bid the contractor can re-submit revised bid any number of times but before last time and date of submission of bid as notified.
4. While submitting the revised bid, contractor can revise the rate of one or more item(s) any number of times (he need not re-enter rate of all the items) but before last time and date of submission of bid as notified.
5. When bids are invited in three stage system and if it is desired to submit revised financial bid then it shall be mandatory to submit revised financial bid. If not submitted then the bid submitted earlier shall become invalid.
6. On opening date, the contractor can login and see the bid opening process.
7. Contractor can upload documents in the form of **JPG** format and **PDF** format.
8. It is mandatory to upload scanned copies of all the documents as stipulated in the bid document. If such document is not uploaded his bid will become invalid and shall be rejected.
9. If the contractor is found ineligible after opening of bids, his bid shall become invalid and shall be rejected.
10. If any discrepancy is noticed between the documents as uploaded at the time of submission of bid and hard copies as submitted physically by the contractor the bid shall become invalid and shall be rejected.
11. Contractor must ensure to quote rate of each item. The column meant for quoting rate in figures appears in pink colour and the moment rate is entered, it turns sky blue.

In addition to this, while selecting any of the cells a warning appears that if any cell is left blank the same shall be treated as "0".

Therefore, if any cell is left blank and no rate is quoted by the bidder, rate of such item

shall be treated as “0” (ZERO).

However, if a tenderer quotes nil rates against each item in item rate tender or does not quote any percentage above/below on the total amount of the tender or any section/subhead in percentage rate tender, the tender shall be treated as invalid and will not be considered as lowest tenderer

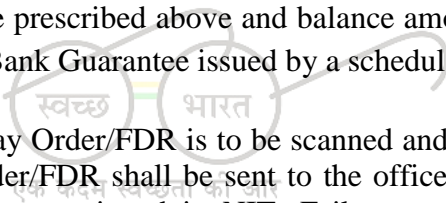
12. **Payment of cost of Tender documents:-** The collection of cost of Tender documents is dispensed away with, as there is no physical supply of tender documents and also to have absolute anonymity of the bidders participating in e-procurement solution. The bidders can view/download the tender documents, from the <http://govtprocurement.delhi.gov.in>.
13. **Submission of bids:** The bidders who are desirous of participating in ‘e’ procurement shall submit their price bids in the standard formats prescribed in the Tender documents, displayed at <http://govtprocurement.delhi.gov.in>. The bidder should upload the scanned copies of all the relevant certificates, documents etc., on the <http://govtprocurement.delhi.gov.in> in support of their price bids. The bidder shall sign on all the statements, documents, certificates uploaded by him, owning responsibility for their correctness/authenticity.
14. **Payment of Bid Security (Earnest Money Deposit):** The EMD shall be in the form of Pay Order/FDR of a scheduled bank issued in favour of Registrar, GGSIPU, New Delhi have to be deposited. 50% of earnest money or Rs.20 lakh, whichever is less, will have to be deposited in the shape prescribed above and balance amount of earnest money can be accepted in the form of Bank Guarantee issued by a scheduled bank.  

Zerox copy of the DD/Pay Order/FDR is to be scanned and uploaded alongwith the Bid, and the original Pay Order/FDR shall be sent to the office of EE, UWD so as to reach before the date and time mentioned in NIT. Failure to furnish the original DD/Pay Order/FDR as EMD and other documents before the date and time mentioned in NIT will entail rejection of bids.
15. **Price Bid Opening:-** The Price Bids will be opened online by the Executive Engineer, UWD at the specified date & time and the result will be displayed on the <http://govtprocurement.delhi.gov.in> which can be seen by all the bidders who participated in the tenders.
16. **Processing of Tenders:** The concerned officer/officers will evaluate and process the tenders as done in the conventional tenders and will communicate the decision to the bidder online.
17. **Participation of Bidders at the time of opening of bids:** Bidders have two options to participate in tendering process at the time of opening of Bids:
  - i) Bidders can come to the place of opening of bids (electronically) as done in the conventional tender process.
  - ii) Bidders can see the process online.
18. **Signing of agreement:** After the award of the contract, an agreement shall be signed as done in conventional tenders.



# **GURU GOBIND SINGH INDRAPRASTHA UNIVERSITY**

## **Tender Document**

Name of Work: A/A GGSIP University, Dwarka Campus,  
New Delhi

Sub Head: Setting up research lab

एक कदम स्वच्छता की ओर

**Executive Engineer  
University Works Division  
Ground Floor, Library Block,  
GGSIPU, Sector- 16C, Dwarka,  
New Delhi – 110078  
Contact : 25302291**

# **Volume – I**

**General Conditions**

**Special Conditions**

**Particular Specification**



## INDEX

Name of Work: A/A GGSIP University, Dwarka Campus, New Delhi

**Sub Head:** Setting up research lab

<b>S.No.</b>	<b>Description</b>	<b>Page Nos.</b>
1.	Press Notice for News Paper	1
2.	Notice Inviting e-Tender for Website	2-3
3.	Information and Instructions for Contractors for E-Tendering Forming Part of NIT and to be posted on Website	4-5
4.	Notice Inviting e-Tender	9-12
5.	Integrity Pact	13-19
6.	Letter of submission	20-21
7.	General Rules and Directions	22-24
8.	Conditions of Contract	25-27
9.	Form of Performance Security and Earnest Money Deposit– Bank Guarantee Bond	28-31
10.	Proforma of Schedules A to F	32-35
11.	Special Conditions, General & Particular Specification & Drawing	36-52
12.	Schedule of Quantities	53-60



## Notice Inviting e-Tender

**CPWD-6**

Online Item rate tenders are invited on behalf of GGSIPU from approved and eligible contractors as per eligibility criteria through e- procurement portal for the work:- :

Name of work:- A/A GGSIP University, Dwarka Campus, New Delhi

Sub Head : Setting up research lab

1. The work is estimated to cost **Rs.14,32,194/-**-This estimate, however, is given merely as a rough guide.

1. A) The bidders who fulfill the following requirements shall be eligible to apply. Joint ventures are not accepted. The firm:

a) Should have satisfactorily completed three similar work each of value **Rs. 5,72,878/-** or two similar work each of value **Rs.8,59,316/-** or one similar work each of value **Rs.11,45,755/-** in last 7 years ending the last date of receipt of tenders. The completed value of works shall be enhanced @ 7% per annum to bring it to the current value upto last date of receipt of tenders. Similar work shall mean Supply Installation Testing and Commissioning of Modular Lab furniture including fumehood in Central Govt department, State Govt. department, Central/State PSU's Autonomous organization, Educational Institutions.

**Note: Note:** Copy of performance certificate duly issued by not below rank of Executive Engineer or equivalent to be submitted. Certificate of private institution should be supported by Form 26AS/TDS certificate. The certificate should clearly indicate scope of work, date of completion, completed value, name of work, agreement/order no., date of start etc. to verify eligibility wherever required, the certificate should be supported by schedule/final bill (certified) to establish similarity.

b) Should have valid GST registration or proof of having applied for obtaining the same.

c) Upto date VAT return of last quarter.

d) Should have valid Pan no.

e) Should furnish an affidavit for not subletting the work as under:-

“I/We undertake and confirm that eligible similar work(s) has/have not been got executed through another contractor on back to back basis. Further that, if such a violation comes to the notice of Department, then I/We shall be debarred for tendering in GGSIPU contracts in future forever. Also, if such a violation comes to the notice of Department before date start of work, the Engineer-in-Charge shall be free to forfeit the entire amount of earnest Money Deposit/Performance Guarantee.”

2. Agreement shall be drawn with the successful tenderer on prescribed Form No. CPWD 8 which is available as a Govt. of India Publication. Tenderer shall quote his rates as per various terms and conditions of the said form which will form part of the agreement.

3. The time allowed for carrying out the work will be **45 days** from the date of start as defined in Schedule 'F' or from the 1<sup>st</sup> date of handing over of the site, whichever is later, in accordance with the phasing, if any, as indicated in the tender documents.

4. The site for the work is available.

5. Tender documents consisting of plans, specifications, the schedule of quantities of the various types of items to be executed and the set of terms and conditions of contract to be complied with and other necessary documents except Standard General Conditions Of Contract Form can be seen from website <http://govtprocurement.delhi.gov.in> or [www.ipu.ac.in](http://www.ipu.ac.in) free of cost.

6. After submission of the bid the contractor can re-submit revised bid any number of times but before last time and date of submission of bid as notified.
7. While submitting the revised bid, contractor can revise the rate of one or more item(s) any number of times (he need not re-enter rate of all the items) but before last time and date of submission of bid as notified.
8. When bids are invited in three stage system and if it is desired to submit revised financial bid then it shall be mandatory to submit revised financial bid. If not submitted then the bid submitted earlier shall become invalid.
9. Earnest money deposit amounting to **Rs. 28,644/-** in the form of Demand Draft or Pay order on fixed deposit receipt (**drawn in favour of Registrar GGSIPU, New Delhi**) or Bank Guarantee of any Scheduled Bank shall be scanned and uploaded to the e-tendering website within the period of tender submission and original should be deposited in office of **EE UWD GGSIPU,GF Library Block at GGSIPU Sec 16C Dwarka Campus New Delhi-110078** in an envelope marked 'EMD' before the stipulated date and time. The Name of Work, NIT No., due date of opening should be mentioned on the envelope. A part of earnest money is acceptable in the form of Bank Guarantee also. In such case, 50% of earnest money or Rs.20 lakh, whichever is less, will have to be deposite in shape prescribed above, and balance in shape of Bank Guarantee of any scheduled bank which is to be scanned and uploaded by the intending bidders.

Copy of Enlistment order of CPWD in appropriate class, copy of PAN card, GST registration or proof of applied for obtaining the same, VAT return of last quater, shall be scanned and uploaded to the e-tendering website within the period of tender submission and certified copy of each shall be deposited by lowest bidder within 7 days of opening of financial bid.

Online tender documents submitted by intending bidders shall be opened only of those bidders, whose Earnest Money Deposit, and other documents placed in the envelope are found in order.

**The bid submitted shall be opened at 03.30 P.M. on 30/08/2017.**

10. A pre-bid meeting held on 18/08/2017 at 11:00 AM in the Confrence Room of University Works Division, Library Block for resolve the query related to this work from the agency.
11. The bid submitted shall become invalid if:
  - i. The bidder is found ineligible.
  - ii. The bidder does not upload all the documents as stipulated in the bid document.
  - iii. If the bidder does not submit EMD in original before the last date as notified.
  - iv. if a tenderer quotes nil rates against each item in item rate tender or does not quote any percentage above/below on the total amount of the tender or any section/subhead in percentage rate tender, the tender shall be treated as invalid and will not be considered as lowest tenderer
12. The contractor whose tender is accepted will be required to furnish performance guarantee of 5% (Five Percent) of the tendered amount within the period specified in Schedule 'F'. This guarantee shall be in the form of cash (in case guarantee amount is less than Rs.10,000/-) or Deposit at call receipt of any scheduled bank / Banker's cheque of any scheduled bank / demand draft of any scheduled bank / pay order of any scheduled bank (in case guarantee amount is less than Rs.1,00,000/-) or Government Securities or Fixed Deposit Receipts or Guarantee bonds of any Scheduled Bank or the State Bank of India in accordance with the prescribed form. In case the contractor fails to deposit the said performance guarantee within the period as indicated in Schedule 'F', including the extended period if any, the Earnest Money deposited by the contractor shall be forfeited automatically without any notice to the contractor.
13. Intending Tenderers are advised to inspect and examine the site and its surroundings and satisfy themselves before submitting their tenders as to the nature of the ground and sub-soil (so far as is practicable), the form and nature of the site, the means of access to the site, the accommodation they may require and in general shall themselves obtain all necessary information as to risks, contingencies and other circumstances which may influence or affect their tender. A tenderer shall be deemed to have full knowledge of the site whether he inspects it or not and no extra charges consequent on any misunderstanding or otherwise shall be allowed. The tenderer shall be responsible for arranging and maintaining at his own cost all materials, tools and plants, water, electricity access, facilities for workers and all other services required for executing the work unless otherwise specifically provided

for in the contract documents. Submission of a tender by a tenderer implies that he has read this notice and all other contract documents and has made himself aware of the scope and specifications of the work to be done and of conditions and rates at which stores, tools and plant, etc. will be issued to him by the Government and local conditions and other factors having a bearing on the execution of the work.

14. The description of the work is as follows:  
Copies of other drawing and documents pertaining to the works will be open for inspection by the tenderers at the office of above mentioned officer. Tenderers are advised to inspect and examine the site and its surroundings and satisfy themselves before submitting their tenders as to the nature of the ground and sub-soil (so far as is practicable), the form and nature of the site, the means of access to the site, the accommodation they may require and in general shall themselves obtain all necessary information as to risks, contingencies and other circumstances which may influence or affect their tender. A tenderer shall be deemed to have full knowledge of the site whether he inspects it or not and no extra charge consequent on any misunderstanding or otherwise shall be allowed. The tenderer shall be responsible for arranging and maintaining at his own cost all materials, tools & plants, water, electricity access, facilities for workers and all other services required for executing the work unless otherwise specifically provided for in the contract documents. Submission of a tender by a tenderer implies that he has read this notice and all other contract documents and has made himself aware of the scope and specifications of the work to be done and of conditions and rates at which stores, tools and plant, etc. will be issued to him by the Government and local conditions and other factors having a bearing on the execution of the work.
15. The competent authority on behalf of the Registrar of GGSIPU, does not bind itself to accept the lowest or any other tender and reserves to itself the authority to reject any or all the tenders received without the assignment of any reason. All tenders in which any of the prescribed condition is not fulfilled or any condition including that of conditional rebate is put forth by the tenderer shall be summarily rejected.
16. Canvassing whether directly or indirectly, in connection with tenders is strictly prohibited and the tenders submitted by the contractors who resort to canvassing will be liable to rejection.
17. The competent authority on behalf of the REGISTRAR GGSIPU reserves to himself the right of accepting the whole or any part of the tender and the tenderer shall be bound to perform the same at the rate quoted.
18. The contractor shall not be permitted to tender for works in the GGSIPU Circle, responsible for award and execution of contracts in which his near relative is posted as Divisional Accountant or as an officer in any capacity between the grades of Superintending Engineer and Junior Engineer (both inclusive). He shall also intimate the names of persons who are working with him in any capacity or are subsequently employed by him and who are near relatives to any gazetted officer in GGSIPU, Any breach of this condition by the contractor would render him liable to be removed from the approved list of contractors of this department.
19. No Engineer of gazetted rank or other gazetted officer employed in Engineering or Administrative duties in an Engineering Department of the Government of India is allowed to work as a contractor for a period of one year after his retirement from Government service, without the previous permission of the Government of India in writing. This contract is liable to be cancelled if either the contractor or any of his employees is found any time to be such a person who had not obtained the permission of the Government of India as aforesaid before submission of the tender or engagement in the contractor's service.
20. The tender for the works shall remain open for acceptance for a period of **Ninety days** from the date of opening of tenders. If any tenderer withdraws his tender before the said period or issue of letter of acceptance, whichever is earlier, or makes any modifications in the terms and conditions of the tender which are not acceptable to the department, then the Government shall, without prejudice to any other right or remedy, be at liberty to forfeit 50% of the said earnest money as aforesaid. Further, the tenderer shall not be allowed to participate in the re-tendering process of the work.
21. This Notice Inviting Tender shall form a part of the contract document. The successful tenderer /contractor, on acceptance of his tender by the Accepting Authority, shall, within 15 days from the stipulated date of start of the work, sign the contract consisting of: -

- (a) The Notice Inviting Tender, all the documents including additional conditions, specifications and

drawings, if any, forming the part of the tender as uploaded at the time of invitation of tender and acceptance thereof together with any correspondence leading thereto.

- (b) Standard CPWD Form 8 with up-to-date correction slips as applicable including GCC 2014 issued by CPWD as on date.
- (c) Integrity Pact.

**Executive Engineer  
UWD, GGSIPU**



## INTEGRITY PACT

To

\_\_\_\_\_  
\_\_\_\_\_  
\_\_\_\_\_

Sub: NIT No. 23/EE/UWD/Civil/2017-18 (Second call) for the work “A/A GGSIP University, Dwarka Campus, New Delhi. SH :- Setting up research lab”.

Dear Sir,

It is here by declared that GGSIPU is committed to follow the principle of transparency, equity and competitiveness in public procurement.

The subject Notice Inviting Tender (NIT) is an invitation to offer made on the condition that the Bidder will sign the integrity Agreement, which is an integral part of tender/bid documents, failing which the tenderer/bidder will stand disqualified from the tendering process and the bid of the bidder would be summarily rejected.

This declaration shall form part and parcel of the Integrity Agreement and signing of the same shall be deemed as acceptance and signing of the Integrity Agreement on behalf of the GGSIPU.

Yours faithfully

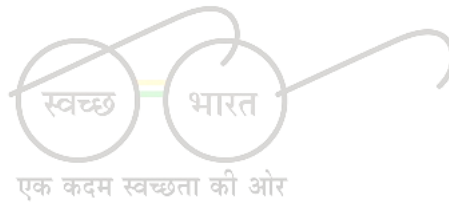

Executive Engineer  
(University Works Division)

## **INTEGRITY PACT**

To

Executive Engineer,  
GGSIPU, Sector 16C  
Dwarka, New Delhi-78

Sub: Submission of Tender for the work of “A/A GGSIP University, Dwarka Campus, New Delhi SH :- Setting up research lab”.

Dear Sir,

I/We acknowledge that GGSIPU is committed to follow the principles thereof as enumerated in the Integrity Agreement enclosed with the tender/bid document.

I/We agree that the Notice Inviting Tender (NIT) is an invitation to offer made on the condition that I/We will sign the enclosed Integrity Agreement, which is an integral part of tender documents, failing which I/We will stand disqualified from the tendering process. I/We acknowledge that **THE MAKING OF THE BID SHALL BE REGARDED AS AN UNCONDITIONAL AND ABSOLUTE ACCEPTANCE** of this condition of the NIT.

I/We confirm acceptance and compliance with the Integrity Agreement in letter and spirit and further agree that execution of the said Integrity Agreement shall be separate and distinct from the main contract, which will come into existence when tender/bid is finally accepted by GGSIPU. I/We acknowledge and accept the duration of the Integrity Agreement, which shall be in the line with Article 1 of the enclosed Integrity Agreement.

I/We acknowledge that in the event of my/our failure to sign and accept the Integrity Agreement, while submitting the tender/bid, GGSIPU shall have unqualified, absolute and unfettered right to disqualify the tenderer/bidder and reject the tender/bid in accordance with terms and conditions of the tender/bid.

Yours Faithfully

(Duly authorized signatory of the Bidder)

## INTEGRITY PACT

### INTEGRITY AGREEMENT

THIS Integrity Agreement is made at \_\_\_\_\_ on this \_\_\_\_\_ day of \_\_\_\_\_ 20\_\_\_\_\_

#### BETWEEN

GGSIU represented through Executive Engineer, UWD, (Hereinafter referred as the 'Principal/Owner', which expression shall unless repugnant to the meaning or context hereof include its successors and permitted assigns )

#### AND

\_\_\_\_\_ through \_\_\_\_\_ (Hereinafter referred as the "Bidder/Contractor" and which expression shall unless repugnant to the meaning or context hereof include its successors and permitted assigns)

#### Preamble

WHEREAS the Principal/Owner has floated the Tender (NIT No. 23/EE/UWD/Civil/2017-18 (Second call)) (hereinafter referred to as "Tender/Bid") and intends to award, under laid down organizational procedure, contract for A/A GGSIP University, Dwarka Campus, New Delhi SH :- Setting up research lab (Name of Work) hereinafter referred to as the "Contract".

And WHEREAS the Principal/Owner values full compliance with all relevant laws of the land, rules, regulations, economic use of resources and of fairness/transparency in its relation with its Bidder(s) and Contractor(s).

AND WHEREAS to meet the purpose aforesaid both the parties have agreed to enter into this Integrity Agreement(hereinafter referred to as "Integrity Pact" or "Pact"), the terms and conditions of which shall also be read as integral part and parcel of the Tender/Bid documents and Contract between the parties.

NOW, THEREFORE, in consideration of mutual covenants in this pact, the parties hereby agree as follows and this pact witnesses as under:

#### Article 1: Commitment of the Principal/Owner

- 1) The Principle/Owner commits itself to take all measures necessary to prevent corruption and to observe the following principles:
  - a) No employee of the Principal/Owner, personally or through any of his/her family members, will in connection with the Tender, or the execution of the Contract, demand, take a promise for or accept, for self or third person, any material or immaterial benefit which the person is not legally entitled to.
  - b) The Principal/Owner will, during the Tender process, treat all Bidder(s) with equity and reason. The Principal/Owner will, in particular, before and during the Tender process, provide to all Bidder(s) the same information and will not

provide to any Bidder(s) confidential/additional information through which the Bidder(s) could obtain an advantage in relation to the Tender process or the Contract execution.

- c) The Principal/Owner shall endeavour to exclude from the Tender process any person, whose conduct in the past has been of biased nature.
- 2) If the Principal/Owner obtains information on the conduct of any of its employees which is a criminal offence under the Indian Penal code (IPC)/Prevention of Corruption Act, 1988 (PC Act) or is in violation of the principles herein mentioned or if there be a substantive suspicion in this regard, the Principal/Owner will inform the Chief Vigilance Officer and in addition can also initiate disciplinary actions as per its internal laid down policies and procedures.

## **Article 2: Commitment of the Bidder(s)/Contractor(s)**

- 1) It is required that each Bidder/Contractor (including their respective officers, employees and agents) adhere to the highest ethical standards, and report to the Government/Department all suspected acts of **fraud or corruption or Coercion or Collusion** of which it has knowledge or becomes aware, during the tendering process and throughout the negotiation or award of a contract.
- 2) The bidder(s)/Contractor(s) commits himself to take all measures necessary to prevent corruption. He commits himself to observe the following principles during his participation in the Tender process and during the Contract execution:
  - a) The bidder(s)/Contractor(s) will not, directly or through any other person or firm, offer, promise or give to any of the Principal/Owner's employees involved in the Tender process or execution of the Contract or to any third person any material or other benefit which he/she is not legally entitled to, in order to obtain in exchange any advantage of any kind whatsoever during the Tender process or during the execution of the Contract.
  - b) The Bidder(s)/Contractor(s) will not enter with other Bidder(s) into any undisclosed agreement or understanding, whether formal or informal. This applies in particular to prices, specifications, certifications, subsidiary contracts, submission or non-submission of bids or any other actions to restrict competitiveness or to cartelize in the bidding process.
  - c) The Bidder(s)/Contractor(s) will not commit any offence under the relevant IPC/PC Act. Further the Bidder(s)/Contractor(s) will; not use improperly; ( for the purpose of competition or personal gain), or pass on to others, any information or documents provided by the Principal/Owner as part of the business relationship, regarding plans, technical proposals and business details, including information contained or transmitted electronically.
  - d) The Bidder(s)/Contractor(s) of foreign origin shall disclose the names and addresses of agents/representatives in India, if any. Similarly Bidder(s)/Contractor(s) of Indian Nationality shall disclose names and addresses of foreign agents/representatives, if any. Either the Indian agent on behalf of the foreign principal or the foreign principal directly could bid in a tender but not both. Further, in cases where an agent participate in a tender on behalf of one manufacturer, he shall not be allowed to quote on behalf of



another manufacturer along with the first manufacturer in a subsequent/parallel tender for the same item.

- e) The Bidder(s)/Contractor(s) will, when presenting his bid, disclose any and all payments he has made, is committed to or intends to make to agents, brokers or any other intermediaries in connection with the award of the Contract.
- 3) The Bidder(s)/Contractor(s) will not instigate third persons to commit offences outlined above or be an accessory to such offences.
- 4) The Bidder(s)/Contractor(s) will not, directly or through any other person or firm indulge in fraudulent practice **means a willful misrepresentation or omission of facts or submission of fake/forged documents in order to induce public official to act in reliance thereof, with the purpose of obtaining unjust advantage by or causing damage to justified interest of other and/or to influence the procurement process to the detriment of the Government interests.**
- 5) The Bidder(s)/Contractor(s) will not, directly or through any other person or firm use Coercive Practices (means the act of obtaining something, compelling an action or influencing a decision through intimidation, threat or the use of force directly or indirectly, where potential or actual injury may befall upon a person, his/her reputation or property to influence their participation in the tendering process).

### **Article 3: Consequences of Breach**

Without prejudice to any rights that may be available to the Principal/Owner under law or the Contract or its established policies and laid down procedures, the Principal/Owner shall have the following rights in case of breach of this Integrity Pact by the Bidder(s)/Contractor(s) and the Bidder/Contractor accepts and undertakes to respect and uphold the Principal/Owner's absolute right:

- 1) If the Bidder(s)/Contractor(s), either before award or during execution of Contract has committed a transgression through a violation of Article 2 above or in any other form, such as to put his reliability or credibility in question, the Principal/Owner after giving 14 days notice to the contractor shall have powers to disqualify the Bidder(s)/Contractor(s) from the Tender process or terminate/determine the Contract, if already executed or exclude the Bidder/Contractor from future contract award processes. The imposition and duration of the exclusion will be determined by the severity of transgression and determined by the Principal/Owner. **Such exclusion may be forever or for a limited period as decided by the Principal/Owner.**
- 2) **Forfeiture of EMD/Performance Guarantee/Security Deposit:** If the Principal/Owner has disqualified the Bidder(s) from the Tender process prior to the award of the Contract or terminated/determined the Contract or has accrued the right to terminate/determine the Contract according to Article 3(1) the principal/owner apart from exercising any legal right that may have accrued to the Principal/Owner, may in its considered opinion forfeit the entire amount of Earnest Money Deposit, Performance Guarantee and Security Deposit of the Bidder/Contractor.
- 3) **Criminal Liability:** If the Principal/Owner obtains knowledge of conduct of a Bidder or Contractor, or of an employee or a representative or an associate of a Bidder or Contractor which constitutes corruption within the meaning of IPC Act, or if the

- 4) Principal/Owner has substantive suspicion in this regard, the Principal/Owner will inform the same to law enforcing agencies for further investigation.

#### **Article 4: Previous Transgression**

- 1) The bidder declares that no previous transgressions occurred in the last 5 year with any other Company in any country confirming to the anticorruption approach or with Central Government or State Government or any other Central/State Public Sector Enterprises in India that could justify his exclusion from the Tender process.
- 2) If the Bidder makes incorrect statement on this subject, he can be disqualified from the Tender process or action can be taken for banning of business dealings/holiday listing of the Bidder/Contractor as deemed fit by the Principal/Owner.
- 3) If the Bidder/Contractor can prove that he has resorted/recouped the damage caused by him and has installed a suitable corruption prevention system, the Principal/Owner may, at its own discretion, revoke the exclusion prematurely.

#### **Article 5: Equal Treatment of all Bidders/Contractors/Subcontractors**

- 1) The Bidder(s)/Contractor(s) undertake(s) to demand from all subcontractors a commitment in conformity with this Integrity Pact. The Bidder/Contractor shall be responsible for any violation (s) of the principles laid down in this agreement/Pact by any of its Sub-contractor/Sub-vendors.
- 2) The Principal/Owner will enter into Pacts on identical terms as this one with all Bidders and Contractors.
- 3) The Principal/Owner will disqualify Bidders, who do not submit, the duly signed Pact between the Principal/Owner and the bidder, along with the Tender or violate its provisions at any stage of the Tender process, from the Tender process.

#### **Article 6: Duration of the Pact**

This Pact begins when both the parties have legally signed it. It expires for the Contractor/Vendor twelve months after the completion of work under the contract or till the continuation of defect liability period, whichever is more and for all other bidders, till the Contract has been awarded.

If any claim is made/lodged during the time, the same shall be binding and continue to be valid despite the lapse of this Pacts as specified above, unless it is discharged/determined by the Competent Authority, GGSIPU.

#### **Article 7: Other Provisions**

- 1) This pact is subject to Indian Law, place of performance and jurisdiction is the **Head quarters of the Division** of the Principal/Owner, who has floated the Tender.
- 2) Changes and supplements need to be made in writing. Side agreements have not been made.
- 3) If the Contractor is a partnership or a consortium, this Pact must be signed by all the partners or by one or more partner holding power of attorney signed by all partners

- 4) and consortium members. In case of a Company, the Pact must be signed by a representative duly authorized by board resolution.
- 5) Should one or several provisions of this pact turn out to be invalid; the remainder of this Pact remains valid. In this case, the parties will strive to come to an agreement to their original intentions.
- 6) It is agreed term and condition that any dispute or difference arising between the parties with regard to the terms of this Integrity Agreement/Pact or any action taken by the Owner/Principal in accordance with this **Integrity agreement /pact interpretation thereof shall not be subject to arbitration.**

#### **Article 8: Legal and Prior Rights**

All rights and remedies of the parties hereto shall be in addition to all the other legal rights and remedies belonging to such parties under the Contract and/or law and the same shall be deemed to be cumulative and not alternative to such legal rights and remedies aforesaid. For the sake of brevity, both the Parties agree that this Integrity Pact will have precedence over the Tender/Contract documents with regard any of the provisions covered under this Integrity Pact.

IN WITNESS WHERE OF the parties have signed and executed this Integrity Pact at the place and date first above mentioned in the presence of following witnesses:

\_\_\_\_\_  
(For and on behalf of Principal/Owner)

\_\_\_\_\_  
(For and on behalf of Bidder/Contractor)

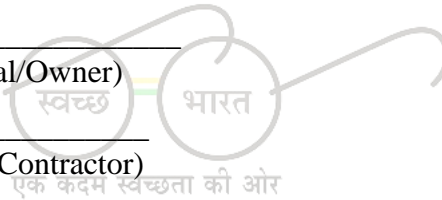

WITNESSES:

1. \_\_\_\_\_
2. \_\_\_\_\_

Place:

Dated:

## Letter of Submission Item rate Tender

(A) Tender for work of A/A GGSIP University, Dwarka Campus, New Delhi

**Sub Head:** Setting up research lab

- i) To be submitted by **15.00 HRS hours up to 30/08/2017** to Executive Engineer. UWD, Ground Floor, Library Block, GGSIPU, Sector-16C, Dwarka, New Delhi-110078
- ii) To be opened in presence of tenderers who may be present at **15.30 hours on - 30/08/2017** in the office of **Ex Engr**, UWD, Ground Floor, Library Block, GGSIPU, Sector-16C, Dwarka, New Delhi-110078

Issued to -----

Signature of officer issuing the documents -----

Designation -----

Date of Issue -----

  
**TENDER**

I/ We have read and examined the Notice inviting tender, specifications applicable, Drawings & Designs, General Rules and Directions, Conditions of Contract, clauses of contract, special condition, particular Specification, Schedule of Quantities & other documents and Rules referred to in the conditions of contract and all other contents in the tender document for the work.

I/We hereby tender for the execution of the work specified for the GGSIPU within the time specified in Schedule 'F', viz., schedule of quantities and in accordance in all respects with the specifications, designs, drawings and instructions in writing referred to in Rule-1 of General Rules and Directions and in Clause 11 of the Conditions of contract and with such materials as are provided for, by, and in respects in accordance with, such conditions so far as applicable.

We agree to keep the tender open for Ninety (90) days from the due date of opening of tender/ninety days from the date of opening of financial bid in case tenders are invited on 2/3 envelop system and not to make any modifications in its terms and conditions.

The earnest money of **Rs. 28,644/-** has been deposited in the shape of fixed deposit receipt of a scheduled bank/ demand draft of a scheduled bank/bank guarantee of scheduled bank issued in favour of Registrar, GGSIPU. If I/we, fail to furnish the prescribed performance guarantee within prescribed period, I/We agree that the said GGSIPU or his successors in office shall without prejudice to any other right or remedy, be at liberty to forfeit the said earnest money absolutely. Further, if I/we fail to commence work as specified, I/we agree that GGSIPU or his successors in office shall without prejudice to any other right or remedy available in law, be at liberty to

forfeit the said earnest money and the performance guarantee absolutely, otherwise the said earnest money shall be retained by him towards security deposit to execute all the works referred to in the tender documents upon the terms and conditions contained or referred to therein and to carry out such deviations as may be ordered, upto maximum of the percentage mentioned in Schedule 'F' and those in excess of that limit at the rates to be determined in accordance with the provision contained in Clause 12.2 and 12.3 of the clauses of contract. Further, I/We agree that in case of forfeiture of earnest money or both Earnest Money & Performance Guarantee as aforesaid, I/We shall be debarred for participation in the retendering process of the work.

I/we hereby declare that I/we shall treat the tender documents drawings and other records connected with the work as secret/ confidential documents and shall not communicate information derived there from to any person other than a person to whom I/we am/are authorized to communicate the same or use the information in any manner prejudicial to the safety of the State.

Date -----

Signature of Contractor  
Postal Address

Witness :  
Address :  
Occupation :

### ACCEPTANCE

The above tender (as modified by you as provided in the letters mentioned hereunder) is accepted by me for and on behalf of the GGSIPU for a sum of Rs.----- (Rupees ---  
-----)

The letters referred to below shall form part of the Agreement :

- a)
- b)
- c)

Executive Engineer,  
University Works Department

**GURU GOBIND SINGH INDRAPRASTHA  
UNIVERSITY SECTOR-16C, DWARKA, NEW DELHI-  
110078**

1. Notice Inviting Tender will state the work to be carried out, as well as the date for submission and opening of tenders and the time allowed for carrying out the work, also the amount of earnest money to be deposited at the time of purchase of tender. The performance Guarantee to be deposited by the successful tenderer and the amount of security deposit to be deducted from bills. Copies of the specifications, designs and drawings and any other documents required in connection with the work signed for the purpose of identification by the officer inviting tender shall also be open for inspection by the contractor at the office of officer inviting tender during office hours.
2. In the event of the tender being submitted by a firm, it must be signed separately by each partner thereof or in the event of the absence of any partner, it must be signed on his behalf by a person holding a power of attorney authorizing him to do so, such power of attorney to be produced with the tender, and it must disclose that the firm is duly registered under the Indian Partnership Act, 1952.
3. Receipts for payment made on account of work, when executed by a firm, must also be signed by all the partners, except where contractors are described in their tender as a firm, in which case the receipts must be signed in the name of the firm by one of the partners, or by some other person having due authority to give effectual receipts for the firm.
4. Any person who submits a tender shall fill up the Schedule of Quantity (Vol.II) form, stating at what rate he is willing to undertake each item of the work. Tenders, which propose any alteration in the work specified in the said form of invitation to tender, or in the time allowed for carrying out the work, or which contain any other conditions of any sort, including conditional rebates, will be summarily rejected. No single tender shall include more than one work, but contractors who wish to tender for two or more works shall submit separate tenders for each. Tender shall have the name and number of the works to which they refer, written on the envelopes.
5. The officer inviting tender or his duly authorized representatives, will open tenders in the presence of any intending contractors who may be present at the time, and will enter the amounts of the several tenders in a comparative statement in a suitable form. In the event of a tender being accepted, a receipt for the earnest money forwarded at the time of purchase of tender shall thereupon be given to the contractor who shall thereupon for the purpose of identification sign copies of the specifications and other documents mentioned in Rule-I. In the event of a tender being rejected, the earnest money of unaccepted tenders shall thereupon be returned to the contractor, without any interest.

6. The officer inviting tenders shall have the right of rejecting all or any of the tenders and will not be bound to accept the lowest or any other tender.
7. The receipt of an accountant or clerk for any money paid by the contractor will not be considered as any acknowledgement or payment to the officer inviting tender and the contractor shall be responsible for seeing that he procures a receipt signed by the officer inviting tender or a duly authorized Cashier.
8. The memorandum of work tendered for and the schedule of materials to be supplied by the department and their issue rates, shall be filled and completed in the office of the officer inviting tender before the tender form is issued. If a form is issued to an intending tenderer without having been so filled in and incomplete, he shall request the officer to have this done before he completes and delivers his tender.
9. The tenderers shall sign a declaration under the official Secret Act 1923, for maintaining secrecy of the tender documents drawings or other records connected with the work given to them. Use of correction fluid, anywhere in tender document is not permitted. Such tender is liable for rejection.
10. Only rates quoted shall be considered. Any tender containing percentage below/above the rates quoted is liable to be rejected. Rates quoted by the contractor in Item rate tender in figures and words shall be accurately filled in so that there is no discrepancy in the rates written in figures and words. However, if a discrepancy is found, the rates which correspond with the amount worked out by the contractor shall unless otherwise proved be taken as correct. If the contractor does not work out the amount of an item or it does not correspond with the rates written either in figures or in words, then the rates quoted by the contractor in words shall be taken as correct. Where the rates quoted by the contractor in figures and in words tally but the amount is not worked out correctly, the rates quoted by the contractor will unless otherwise proved be taken as correct and not the amount. In event no rate has been quoted for any item(s), leaving space both in figure(s), word(s), and amount blank, it will be presumed that the contractor has included the cost of this/these item(s) in other items and rate for such item(s) will be considered as zero and work will be required to be executed accordingly.
11. In the case of any tender where unit rate of any item/ items appear unrealistic, such tender will be considered as unbalanced and in case the tenderer is unable to provide satisfactory explanation, such a tender is liable to be disqualified and rejected.
12. All rates shall be quoted on the tender form (i.e. Schedule of Quantities Vol. II). The amount for each item should be worked out and requisite totals given. Special care should be taken to write the rates in figures as well as in words and the amount in figures only, in such a way that interpolation is not possible. The total amount should be written both in figures and in words. In case of figures, the word 'Rs.' should be written before the figure of rupees and word 'P' after the decimal figures, e.g. 'Rs.2.15 P' and in case of words, the word, 'Rupees' should precede and the word 'Paise' should be written at the end. Unless the rate is in whole rupees and followed by the word 'only' it should invariably be upto two decimal places. While quoting the rate in schedule of quantities, the word 'only' should be written closely following the amount and it should not be written in the next line.

13. i) The contractor whose tender is accepted shall be required to deposit an amount equal to 5% of the tendered value of the work as performance guarantee within the period as specified in schedule-‘F’ in the form of an irrevocable bank guarantee bond of any scheduled bank in accordance with the form prescribed, fixed deposit receipt or demand draft in favour of Registrar, GGSIPU.
- ii) The contractor whose tender is accepted, will also be required to furnish by way of Security Deposit for the fulfillment of his contract, an amount equal to 2.5% of the tendered value of the work. The Security deposit will be collected by deductions from the running bills as well as final bill of the contractor at the rates mentioned above. The Security amount will also be accepted in cash or in the shape of Government Securities. Fixed Deposit Receipt of a Scheduled Bank or State Bank of India will also be accepted for this purpose provided confirmatory advice is enclosed.
14. On acceptance of the tender, the name of the accredited representative(s) of the contractor who would be responsible for taking instructions from the Engineer-in-Charge shall be communicated in writing to the Engineer-in-Charge.
15. Sales Tax/GST, purchase tax, turnover tax or any other tax applicable in respect of this contract shall be payable by the Contractor and GGSIPU will not entertain any claim whatsoever in respect of the same.
16. The contractor shall give a list of both gazetted and non-gazetted GGSIPU employees related to him.
17. The tender for the work shall not be witnessed by a contractor or contractors who himself/themselves has/have tendered or who may and has/have tendered for the same work. Failure to observe this condition would render, tenders of the contractors tendering, as well as witnessing the tender, liable to summary rejection.
18. The tender for composite work includes, in addition to building work, all other works such sanitary and water supply installations drainage installation, civil work, horticulture work, roads and paths etc. The tenderer apart from being a registered contractor (B&R) of appropriate class, must associate himself with agencies of appropriate class which are eligible to tender for sanitary and water supply drainage, civil land horticulture works in the composite tender.
19. The contractor shall comply with the provisions of the Apprentices Act 1961, and the rules and orders issued there under from time to time. If he fails to do so, his failure will be a breach of the contract and the GGSIPU may in his discretion, without prejudice to any other right or remedy available in law, cancel the contract. The contractor shall also be liable for any pecuniary liability arising on account of any violation by him of the provisions of the said Act.



## **CONDITIONS OF CONTRACT**

### **Definitions**

1. The Contract means the documents forming the tender and acceptance thereof and the formal agreement executed between the competent authority on behalf of the GGSIPU and the Contractor, together with the documents referred to therein including these conditions, the specifications, designs, drawings and instructions issued from time to time by the Engineer-in-Charge and all these documents taken together, shall be deemed to form one contract and shall be complementary to one another.
2. In the contract, the following expressions shall, unless the context otherwise requires, have the meanings, hereby respectively assigned to them:
  - i) The expression works or work shall, unless there be something either in the subject or context repugnant to such construction, be construed and taken to mean the works by or by virtue of the contract contracted to be executed whether temporary or permanent, and whether original, altered, substituted or additional.
  - ii) The Site shall mean the land/ or other places on, into or through which work is to be executed under the contract or any adjacent land, path or street through which work, is to be executed under the contract or any adjacent land, path or street which may be allotted or used for the purpose of carrying out the contract.
  - iii) The Agency / Contractor / Tenderer shall mean the individual, firm or company, whether incorporated or not, undertaking the works and shall include the legal personal representative of such individual or the persons composing such firm or company, or the successors of such firm or company and the permitted assigns of such individual, firm or company.
  - iv) The GGSIPU means the Guru Gobind Singh Indraprastha University and his successors.
  - v) The Engineer-in-Charge means the Executive Engineer UWD
  - vi) Accepting Authority shall mean the authority mentioned in Schedule 'F'.
  - vii) Excepted Risk are risks due to riots (other than those on account of contractor's employees), war (whether declared or not) invasion, act of foreign enemies, hostilities, civil war, rebellion revolution, insurrection, military or usurped power, any acts of Government, damages from aircraft, acts of God, such as earthquake, lightening and unprecedented floods, and other causes

over which the contractor has no control and accepted as such by the Accepting Authority or causes solely due to use or occupation by Government of the part of the works in respect of which a certificate of completion has been issued or a cause solely due to Government's faulty design of works.

- viii) Market Rate shall be the rate as decided by the Engineer-in-Charge on the basis of the cost of materials and labour at the site where the work is to be executed plus the percentage mentioned in Schedule 'F' to cover, all overheads and profits.
- ix) Schedule(s) referred to in these conditions shall mean the relevant schedule(s) annexed to the tender papers or the standard Schedule of Rates of the government mentioned in Schedule 'F' hereunder, with the amendments thereto issued upto the date of receipt of the tender.
- x) Department means Guru Gobind Singh Indraprastha University or authorized by GGSIPU to work on their behalf.
- xi) District Specifications means the specifications followed by the State Government in the area where the work is to be executed.
- xii) Tendered value means the value of the entire work as stipulated in the letter of award.

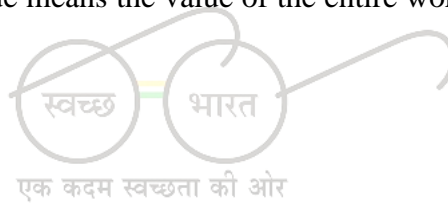

### **Scope and Performance**

3. Where the context so requires, words imparting the singular only also include the plural and vice versa. Any reference to masculine gender shall whenever required include feminine gender and vice versa.
4. Headings and Marginal notes to these General Conditions of Contract shall not be deemed to form part thereof or be taken into consideration in the interpretation or construction thereof or of the contract.
5. The contractor shall be furnished, free of cost one certified copy of the contract documents except standard specifications, Schedule of Rates and such other printed and published documents, together with drawings as may be forming part of the tender papers. None of these documents shall be used for any purpose other than that of this contract.

### **Works to be carried out**

6. The work to be carried out under the Contract shall, except as otherwise provided in these conditions, include all labour, materials, tools, plants, equipment and transport which may be required in preparation of and for and in the full and entire execution and completion of the works. The descriptions given in the Schedule of Quantities

(Schedule-A) shall, unless otherwise stated, be held to include wastage on materials, carriage and cartage, carrying and return of empties, hoisting, setting, fitting and fixing in position and all other labours necessary in and for the full and entire execution and completion of the work as aforesaid in accordance with good practice and recognized principles.

### **Sufficiency of Tender**

7. The Contractor shall be deemed to have satisfied himself before tendering as to the correctness and sufficiency of his tender for the works and of the rates and prices quoted in the Schedule of Quantities, which rates and prices shall, except as otherwise provided, cover all his obligations under the Contract and all matters and things necessary for the proper completion and maintenance of the works.

### **Discrepancies and Adjustment of Errors**

8. The several documents forming the Contract are to be taken as mutually explanatory of one another, detailed drawings being followed in preference to small scale drawing and figured dimensions in preference to scale and special conditions in preference to General Conditions.

8.1 In the case of discrepancy between the schedule of Quantities, the Specifications and/or the Drawings, the following order of preference shall be observed:

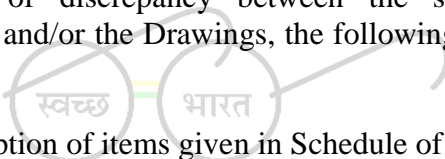
- 
- i) Description of items given in Schedule of Quantities.
  - ii) Technical Specification, Special Conditions, additional conditions General specifications and particular specifications.
  - iii) Drawings.
  - iv) C.P.W.D. Specifications.
  - v) Indian Standard Specifications of B.I.S.
  - vi) Decision of Engineer-in-Charge.

8.2 If there are varying or conflicting provisions made in any one document forming part of the contract, the Accepting Authority shall be the deciding authority with regard to the intention of the document and his decision shall be final and binding on the contractor.

8.3 Any error in description, quantity or rate in Schedule of Quantities or any omission there from shall not vitiate the Contract or release the Contractor from the execution of the whole or any part of the works comprised therein according to drawings and specifications or from any of his obligations under the contract.

## **Form of Performance Security (Guarantee) Bank Guarantee Bond**

1. In consideration of the Guru Gobind Singh Indraprastha University (hereinafter called "The University") having offered to accept the terms and conditions of the proposed agreement between ----- and ----- (hereinafter called "the said Contractor(s)") for the work ----- (hereinafter called "the said agreement") having agreed to production of a irrevocable Bank Guarantee for Rs.----- (Rupees ----- only) as a security/guarantee from the contractor(s) for compliance of his obligations in accordance with the terms and condition in the said agreement.

We, ----- (hereinafter referred as "the Bank") hereby undertake to  
(indicate the name of the Bank)  
pay to the University an amount not exceeding Rs.----- (Rupees ----- only) on demand by the University.

2. We, ----- do hereby undertake to pay the amounts due and  
(indicate the name of the Bank)  
payable under this guarantee without any demure, merely on a demand from the University stating that the amount claimed is required to meet the recoveries due or likely to be due from the said contractor(s). Any such demand made on the bank shall be conclusive as regards the amount due and payable by the bank under this Guarantee. However, our liability under this guarantee shall be restricted to an amount not exceeding Rs.----- (Rupees ----- only).

3. We, the said bank further undertake to pay the University any money so demanded notwithstanding any dispute or disputes raised by the contractor(s) in any suit or proceeding pending before any court or Tribunal relating thereto, our liability under this present being absolute and unequivocal.

The payment so made by us under this bond shall be a valid discharge of our liability for payment there under and the Contractor(s) shall have no claim against us for making such payment.

4. We, ----- further agree that the guarantee herein contained shall  
(indicate the name of the Bank)  
remain in full force and effect during the period that would be taken for the performance of the said agreement and that it shall continue to be enforceable till all the dues of the University under or by virtue of the said agreement have been fully paid and its claims satisfied or discharged or till Engineer-in-Charge on behalf of the University certified that the terms and conditions of the said agreement have been fully and properly carried out by the said Contractor(s) and accordingly discharges this guarantee.

5. We, ----- further agree with the University that the University  
(indicate the name of the Bank)  
shall have the fullest liberty without our consent and without affecting in any manner our obligation hereunder to vary any of the terms and conditions of the said agreement or to extend time of performance by the said Contractor(s) from time to time or to postpone for any time or from time to time any of the powers exercisable by the University against the said contractor(s) and to forbear or enforce any of the terms and conditions relating to the said agreement and we shall not be relieved from our liability by reason of any such variation, or extension being granted to the said Contractor(s) or for any forbearance, act of omission on the part of the University or any indulgence by the University to the said Contractor(s) or by any such matter or thing whatsoever which under the law relating to sureties would, but for this provision, have effect of so relieving us.

6. This guarantee will not be discharged due to the change in the constitution of the Bank or the Contractor(s).

7. We, ----- lastly undertake not to revoke this guarantee except  
(indicate the name of the Bank)  
with the previous consent of the University in writing.

8. This guarantee shall be valid upto ----- unless extended on demand by the University. Notwithstanding anything mentioned above, our liability against this guarantee is restricted to Rs.----- (Rupees ----- only) and unless a claim in writing is lodged with us within six months of the date of expiry or the extended date of expiry of this guarantee all our liabilities under this guarantee shall stand discharged.

Dated the ----- day of ----- for ----- (indicate the name of the Bank)

Signature & Seal of Bank



## FORM OF EARNEST MONEY (BANK GUARANTEE)

WHEREAS, contractor ..... (Name of contractor) hereinafter called “the contractor”) has submitted his tender dated.....(date) for the construction of ..... (name of work) (hereinafter called “ the Tender”)

KNOW ALL PEOPLE by these presents that we ..... (name of bank) having our registered office at ..... (hereinafter called “the Bank”) are bound unto ..... (Name and division of Executive Engineer) (hereinafter called “the Engineer-in-Charge”) in the sum of Rs..... (Rs. In words.....) for which payment well and truly to be made to the said Engineer-in-Charge the Bank binds itself, his successors and assigns by these presents.

SEALED with the Common Seal of the said Bank this..... day of .....20...

THE CONDITIONS of this obligation are:

- (1) If after tender opening the Contractor withdraws his tender during the period of validity of tender (including extended validity of tender) specified in the Form of tender;
- (2) If the contractor having been notified of the acceptance of his tender by the Engineer-in-Charge:
  - a) fails or refuses to execute the Form of agreement in accordance with the instructions to contractor, if required; OR
  - b) fails or refuses to furnish the Performance Guarantee, in accordance with the provisions of tender document and instructions to contractor, OR
  - c) fails or refuses to start the work, in accordance with the provisions of the contract and instructions to contractor, OR
  - d) fails or refuses to submit fresh Bank Guarantee of an equal amount of this Bank Guarantee, against Security Deposit after award of contract.

We undertake to pay to the Engineer-in-Charge up to the above amount upon receipt of his first written demand, without the Engineer-in-Charge having to substantiate his demand, provided that in his demand the Engineer-in-Charge will note that the amount claimed by him is due to him owing to the occurrence of one or any of the above conditions, specifying the occurred condition or conditions.

The Guarantee will remain in force up to and including the date ..... after the deadline for submission of tender as such deadline is stated in the instructions to contractor or as it may be extended by the Engineer-in-Charge, notice of which extension(s) to the Bank is hereby waived. Any demand in respect of this Guarantee should reach the Bank not later than the above date.

**DATE.....**

**SIGNATURE OF THE**

**SEAL**

**BANK**

**WITNESS.....**

**(SIGNATURE, NAME AND ADDRESS**

\* Date to be worked out on the basis of validity period of 6 months from last date of receipt of tender.



# PROFORMA OF SCHEDULES

(Operative Schedules to be supplied separately to each intending tenderer)

## SCHEDULE 'A'

Schedule of quantities - As per (Page 53 TO 60)

## SCHEDULE 'B'

Schedule of materials to be issued to the contractor. NIL

## SCHEDULE 'C'

Tools and plants to be hired to the contractor : NIL

## SCHEDULE 'D'

Extra schedule for specific requirements/ document for the work, if any. - NIL

## SCHEDULE 'E'

Reference to General Conditions of contract.

Name of Work: A/A GGSIP University, Dwarka Campus, New Delhi

**Sub Head:** Setting up research lab

Estimated cost of work : **Rs. 14,32,194/-**

- i) Earnest money : **Rs. 28,644/- (to be returned after submission of performance guarantee)**
- ii) Performance Guarantee : **5% of tendered value.**
- iii) Security Deposit : **2.5% of tendered value.**

## SCHEDULE 'F'

General Rules & Directions:

Officer Inviting Tender : Ex. Engr, UWD, GGSIPU

### Definitions:

2(v) Engineer-in-Charge Ex. Engr, UWD, GGSIPU

2(viii) Accepting Authority Ex. Engr., UWD, GGSIPU

2(x) Percentage on cost of materials and labour to cover all overheads and profits 15%

2(xi) Standard Schedule of Rates DSR 2016

2(xii) Department GGSIPU

9(ii) Contract Form Standard CPWD contract form GCC 2014, Form 7/8 with upto date correction slip.

### Clause 1

- i) Time allowed for submission of Performance Guarantee from the date of issue of letter of acceptance, in days **10 days**



ii) Maximum allowable extension with late fee @ 0.1% per day of Performance Guarantee amount beyond the period provided in (i) above

**5 days**

**Clause 2**

Authority for levy compensation Under clause 2.

**Superintending Engr/Registrar, GGSIPU**

**Clause 2A**

Whether Clause 2A shall be applicable

**Not Applicable**

**Clause 5**

Number of days from the date of issue of letter of acceptance for reckoning date of start

**15 days**

Time allowed for execution of work.

**45 days**

Authority to decide

- a. Extension of time
- b. Rescheduling of milestones
- c. Shifting of date of start in case of delay in handing over of site

Executive Engineer

Executive Engineer

Superintending Engineer/Registrar, GGSIPU

**Clause 6 or 6 A**

Clause Applicable



**6A**

**Clause 7**

Gross work to be done together with net payment/ Adjustment of advances for material collected, if any Since the last such payment for being eligible to Interim payment

**Rs. 3 lakh**

**Clause 7A**

**Not Applicable**

**Clause 10 A**

List of testing equipment to be provided at site

**Nil**

**Clause 10 B(ii)**

Whether clause 10B(ii) is applicable

**No**

**Clause 10 C**

Component of labour expressed as percent of value of work

**Not Applicable**

**Clause 10 CA**

**Not Applicable**

**Clause 10 CC**

Clause 10CC to be applicable in contracts with Stipulated period of completion exceeding the Period shown in next column

**12 months**

Schedule of component of other materials, labour, POL etc for price escalation

Component of Civil (except for materials covered under clause 10CA) / Electrical construction materials expressed as percent of total value of work

Not Applicable

Component of labour expressed as percent of total value of work

Not Applicable

Component of POL expressed as percent Of total value of work

Not Applicable

**Clause 11**

Specifications to be followed for execution of work

CPWD specification 2009 with upto date correction slip/manufacturer specification

**Clause 12**

**Type of Work**

**Original Work**

12.2 & 12.3

Deviation limit beyond which clauses 12.2 & 12.3 shall apply for building work

30%

12.5

i) Deviation limit beyond which clauses 12.2 & 12.3 shall apply for foundation Work (except earth work)

30%

ii) Deviation limit for items in earth work sub head of DSR or related items

100%

**Clause 16**

Competent Authority for deciding reduced rates

Superintending Engr./Registrar  
GGSIPU

**Clause 18**

List of mandatory machinery tools& plants To be deployed by the contractor at site

**As required for completion within time period**

**Clause 25**

Constitution of Dispute Redressal committee

Chairman- Registrar, GGSIPU  
Member-II, Technical Expert appointed by Hon'ble VC

**Clause 36(i)**

Requirement of Technical representative(s) and recovery rate

**Not applicable**

**Clause 42**

(i) (a) Schedule/statement for determining theoretical quantity of cement & bitumen of the basis of Delhi Schedule of Rates 2012 printed by C.P.W.D

(ii) Variations permissible on theoretical quantities.

(a) Cement

For works with estimated cost put to tender not more than Rs. 5 Lakhs.

3% plus/minus

For works with estimated cost put to tender not more than Rs. 5 Lakhs.

2% plus/minus

(b) Bitumen All works

2.5% plus only & nil on minus side.

(c) Steel Reinforcement and structural steel sections for each diameter, section and category

2 plus/minus

(d) All other materials

Nil

#### RECOVERY RATES FOR QUANTITIES BEYOND PERMISSIBLE VARIATION

S.No.	Description of Item	Rates in figures and words at which recovery shall be made from the Contractor	
		Excess beyond permissible variation	Less use beyond the permissible variation
1.	Cement	NIL	Rs. 4,900 /- per MT.
2.	Steel Reinforcement i) Primary Manufacture	NIL	Rs. 39,000/- per MT.

# Special Conditions



### Special Conditions

- 1.0 “CPWD Specifications” wherever appearing in this document would mean Latest edition of CPWD specifications with correction slips issued upto the last date of receipt of tender.
- 2.0 GCC 2014 referred in this document is Govt of India Publication and is available in the market.
  - a) Form 7/8, forming part of ‘GCC 2014’ shall be superceded by this document.
  - b) Wherever “President of India” is appearing in the GCC 2014 same shall be read as GGSIPU.
  - c) Wherever Superintending Engineer is appearing in GCC 2014, it may be read as Superintending Engineer, GGSIPU.
  - d) Wherever CPWD or PWD is appearing in GCC 2014, it may be read as GGSIPU.
- 3.0 Unless otherwise provided in the schedule of quantities the rates tendered by the contractor shall be all-inclusive and shall apply to all heights, levels, depths, leads, lifts including shafts, machine room & stair cases. The rates for all items of work, unless clearly specified otherwise, shall include the cost of all labour, materials, and other inputs involved in the execution of the items.
- 4.0 No foreign exchange shall be made available by the department for the purpose of procurement of equipment, plants, machinery, materials of any kind or any other items required to be carried out in execution of work.
- 5.0 The contractor or his authorized representative should always be available at the site of work to take instructions from Engineer in charge, and ensure proper execution of work.
- 6.0 No work shall commence in the absence of contractor’s engineers and they shall certify in writing about the correctness of layout alignment and shall ensure stability of all structural work such as partition panel and other related items.
- 7.0 All work and materials brought and left upon the ground by the contractor or by his orders for the purpose of forming part of the works, are to be considered to be the property of the GGSIPU and the same are not to be removed or taken away by the contractor or any other person without consent in writing of the Engineer-in-charge but the GGSIPU is not to be in any way responsible for any loss or damage which may happen to or in respect of any such work or materials either by the same being lost or damaged by weather or otherwise.
- 8.0 The contractor shall execute the different items simultaneously, as far as possible, so that minimum breakage and repairs are involved.
- 9.0 The contractor shall take all necessary precautions to prevent any nuisance or inconvenience to the owners, tenants of adjacent properties and to the public in general and to prevent any damage to such properties and any pollution of environment and waterways. He shall make good at his own cost and to the satisfaction of the Engineer-in-Charge, any damage to public or private property whatsoever caused by the execution of the work or by traffic brought thereon by the

contractor. Utmost care shall be taken to keep the noise level to the barest minimum so that no disturbance as far as possible is caused to the occupants/users of adjoining buildings.

- 10.0 All associated activities required for obtaining necessary clearances, permissions, approvals, all licenses etc. as required from all concerned authorities in respect of installation and commissioning shall be the responsibility of the contractor, the cost for which shall be deemed to be included in the rates for various items of work of Schedule of Quantities. However, actual statutory fee paid to the concerned authorities for obtaining approvals if any, shall be reimbursed by the University on production of proof of payment made by the Contractor.
- 11.0 The contractor shall be responsible for watch and ward of all the works, equipment and various materials till complete handing over of works.
- 12.0 Wherever any reference to any Indian Standards Specification occurs in the documents relating to this contract the same shall be inclusive of all amendments issued their to or revisions there of if any, upto the date of receipt of tenders.
- 13.0 The site of work may be at one or more places within the campus and at any floor upto twelve levels for which nothing extra shall be paid. Nothing extra shall be paid for height on external work.
- 14.0 Cess @ 1% of gross value of work done shall be deducted from the payment as per Delhi Building & other Construction Workers Welfare Cess Act 1996 besides other statutory deduction like income tax, GST etc. as applicable.
- 15.0 The contractor shall be fully responsible for rectifying the defect, which may happen during the use up to twenty Four months from the date of completion of the work. The decision of Engineer-in-Charge in this regard shall be final & binding. In case the contractor fails to carry out the said repairs, rectifications, replacement within the specified time, the department shall get the repairs / rectifications / replacement as considered necessary at the cost of the contractor by recovering the cost from the security deposit. In case additional expenditure is incurred by the department on this account, the same shall be borne by the contractor.
- 16.0 The rates quoted by the contractor shall be all inclusive keeping in mind the specifications, special conditions and technical specifications and nothing extra shall be payable whatsoever, unless otherwise specified.
- 17.0 If the work is carried out in more than one shifts or during night to meet the time period of completion or inaccordance with availability of working area, nothing extra shall be paid on this account. The contractor has to work in accordance with programme, time schedule as directed by Engineer-in-Charge.
- 18.0 Contractor shall have to make own arrangement for water & electricity, otherwise 1% of gross amount shall be deducted from the dues of the contractor.
- 19.0 The contractor shall follow the instruction and restrictions imposed by the Administration / Police authorities on the working and movement of labour / material / vehicles etc and nothing extra shall be paid on this account.

20.0 The Contractor shall obtain prior approval from the Engineer-in-charge before placing order for any specific material or engaging any of the specialized agencies.

21.0 Wherever applicable, the Engineer-in-charge may approve any material equivalent to that specified in the tender subject to proof being offered by the Contractor for equivalence to his satisfaction.

In case on non availability of the brand specified in the contract, the Contractor shall submit the documentary evidence of non availability of approved brand and suggest the alternate brand of equivalent quality for the approval of the competent authority. It will be at the discretion of the Engineer-in-Charge to approve or reject the brand suggested by the contractor and approve the name of any other equivalent brand.

22.0. Unless otherwise specified, the brand/make of the material as specified in the item nomenclature, in the particular specifications and in the list of approved materials attached in the tender, shall be used in the work.

S. No.	Material	Brand / Make
1.	Cement	Ultratech, ACC, Vikram 43 Grade, JP Rewa, JK, Birla, Shree Cement.
2.	White Cement	JK, Birla
3.	Water Proofing Compound (Liquid)	Pidiproof Ltd., Cico, Impermo
4.	Melamine Polish	Melamine of Asian Paint, Wudfin of pidilite Industries, Timbertone of ICI Dullex.
5.	Synthetic Enamel Paints	ICI (Dulux),Asian (Apolite),Berger (Luxol),Nerolac (NST)
6.	Primer	Asian, ICI, Berger, Nerolac
7.	Oil Bound Distemper	Asian(Tractor), ICI (Maxilite),Berger(Bison),Nerolac (NAD)
8.	Plastic /Acrylic Emulsion Paint	Asian (Royale), ICI (Velvet), Berger (Luxol Silk), Nerolac (Allscapes)
9.	Premium Acrylic Smooth exterior paint	Out stretch of NITCO, Apex Ultima of Asian, Weather shield max of ICI
10.	Wall putty	Birla, JK, Sakarni
11.	Fire Coating paint	Phoenix, Asian.
12.	Cement Paint	Snowcem Plus, Berger (Durocem Extra) Nerolac with titanium
13.	PVC/ Polypropelene Flooring	Arm Strong, LG
14.	Polymer Modified quick set tile adhesive	Bal Endura, Pidilite
15.	Ply Wood	Kitply, Green ply, Century, Duro
16.	Pre-laminated Particle Board	Novapan, Eco Board, Kitlam, century, merino
17.	Laminate	Marino, Greenlam, Century, Formica

18.	Stainless Steel Screws	Kundan, Arrow
19.	Aluminium Extrusions/ Sections	Hindalco, Indalco, Jindal
20.	Hydraulic Floor spring	Hardwyn, Godrej, Doorking, Everite, KICH, ARCH
21.	Hydraulic Door Closer	Hardwyn, Godrej, Doorking, Everite, KICH, ARCH
22.	S.S. ball bearing hinges	Hettich, D-line.
23.	Stainless steel- Tower bolt, Sliding door bolt, Floor door stopper	Acme, Bolt, Hardwyn
24.	Stainless steel- Handles, Door closer	Ozone, Hardwyn, Shanu Acme
25.	Mortice latch & lock	Godrej, ACME, Hardwyn
26.	Masking taps	Suncontrol, wonder plymer
27.	EPDM Gasket	Roop, Anand, HANU
28.	Structural steel section	TATA, SAIL, RINL, Rama, Capital, Kamdhem
29.	Tubular Steel work (M. S. Pipes)	TATA, Jindal (Hisar), GSF.
30.	Steel	SAIL, TISCO, RINL
31.	Float Glass/ Mirror	Modi Float, Saint Gobain, Asahi
32.	Toughened Glass	Sant Gobain, Emirates, Asahi, Viracon.
33.	Annealed Float Glass	Saint Gobain, Modi Guard, Hindustan Pilkington
34.	Galvanized/Stainless Steel Anchor Fasteners	Hilti, Fischer
35.	Structural Silicon Sealant	Dow Corning, Wacker, GE, Du-pont
36.	GI Pipe	Tata, Jindal (Hissar), Surya
37.	GI fitting	Unik, KS, ICS
38.	Centrifugally Cast Iron Pipe & Fittings	Neco, Kapilansh
39.	CP Brass-Waste, towel rail, soap dish	Jaquar, Parryware, Hindware, Cera
40.	Plastic Connection Pipe	Perryware/Kamal Delux



41.	CP Waste Coupling	Jaquar, Parryware, hindware, Cera
42.	CP Bottle Trap	Perryware / Hindware / Jaquar, Cera
43.	Waste Pipe	Kamal with brass checknut/Viking
44.	Stainless steel sink with or without draining board	Nirali, Hindware, Paryware, Cera, Prayag, Nilkanth
45.	Fumehood	X Gen Fumehood of GD lab solutions or equivalent in Godrej, Keuwanee
46.	CP Brass Fittings	Jaguar, CERA, Parrywre, Prayag, Marc, Hindware
47.	PVC pipe/fitting	Supreme, Prince, Finolex, Kissan
48.	Copper conductor wire FRLS	Sky tone/ Havells/ Finolex
49.	Steel conduit/PVC conduit	BEC/Steel Kraft/NIC/AKG
50.	Modular Switches/Sockets/switch plate	Legrand(Mosaic)/ Crabtree (Athena) or equivalent model of M.K.
51.	GI Box	Legrand(Mosaic)/ Crabtree (Athena) or equivalent model of M.K.
52.	MCB/ MCB DB/Industrial Socket	Legrand /L&T/ GE/ ABB/Schneider/Havells
53.	PVC boxes for Dado trunking	Legrand(Mosaic)/ Crabtree (Athena) or equivalent model of M.K.
54.	Dado Trunking 100(H) X 50 (D)	MK/Legrand or Equalvalent make.

# General Specifications

## 1.0 Scope

- 1.1 The scope of laboratory furniture shall consist of supply of raw material, fabrication, assembling, preparation of design, drawings, supply and erection. Work shall be executed in a well coordinated and professional manner.
- 1.2 All works shall be executed strictly in accordance with the item description, specifications and approved drawings. However in absence of specifications, BIS standards shall be followed along with relevant item description, technical specifications, drawings and manufacturer specifications.
- 1.4 The work shall be executed and measured as per metric dimensions given in schedule of quantities, drawings etc. (F.P.S. units wherever indicated are for guidance only)

## 2.0 Quality & Workman Ship

- 2.1 The specifications are intended for the general description of the work quality and workmanship. The specifications are however not intended to cover the minute details and in its absence the relevant CPWD / BIS standards / manufacturer's specifications or the best trade practices.
- 2.2 All material shall conform to the approved makes of materials specified. The procurement of various materials shall be either from the manufacturers or their authorized dealers so that there is no duplicate / spurious makes are used. Notwithstanding all above, contractor shall be held responsible for the execution of works and use of proper best available quality of materials as per the tender specifications. For the items/materials not appearing in the list, the decision of Engineer-in-charge shall be final and binding.
- 2.3 The contractor shall arrange inspection at factory of the works by Engineer – in – Charge or his authorized representative, if so desired. Contractor will have no claim if the material/finished product brought at site are rejected by Engineer-in-Charge in part or full lot due to bad workmanship / quality. Such material/finished product will not be measured and paid and the contractor shall remove the same from the site of work within 7 days after the written instructions in this regard are issued by engineer-in-Charge or his authorized representative.
- 2.4 The contractor shall produce all materials in advance so that there is sufficient time for testing and approving of the material and clearance of the same for use in work. The contractor shall produce test certificates of all the material in respect of their conformation to the relevant Indian standards / tender specifications. All tests required for the materials as desired by the Engineer-in-Charge shall be at the contractors cost

2.4 Testing may also be carried out at the discretion of the Engineer-in-Charge, from the lot of finished product brought at site by the contractor. In case such tests have been carried out by the principal manufacturer at its testing facility, the same will may be provided by the contractor for consideration.

### **3.0 Drawings & Execution of Work**

3.1 The work shall be executed as per the layout approved by Engineer – In Charge. The contractor shall prepare the layout on the basis of the layout attached in this tender document keeping in view the site requirements and seek approval from engineer in charge.

3.2 Upon approval of layout, the contractor shall prepare shop drawings for fabrication / assembling / joineries etc. All manufacturing, fabrication, assembling work in connection with the item shall be under taken by the contractor after the approval of shop drawings by the Engineer – in Charge.

### **4.0 Fabrication**

4.1 The steel frames, panels and shutters shall be made form Prime Quality CRCA (Cold Rolled Cold Annealed) Steel.

4.2 The height adjustable leg shall ensure that the leg is securely held in place during the mounting and moving of the cabinet. It shall have a wide foot of dia 35 – 40 mm. Height adjustable can be easily done either manually or by screw driver. The black plastic has a load bearing capacity 450 kg/each. High precision double extension ball slides shall be provided in the cabinet drawers. These shall be the best fitting slides and the drawers shall open fully.

4.3 All CRCA steel sheet components should be fabricated by precision shearing, leveling, notching, piercing, machines to achieve consolidated dimensions within close tolerances under the strict quality checks and assembled with the aid of fixtures. Exposed welding marks should be polished smooth to improve aesthetic. Corner intersections of vertical and horizontal members should in the same plane with bolted joints and should be suitably aligned.

### **5.0 Finishing & Surface Treatment :**

After the component parts in case of Steel furniture have been completely welded together and before finishing, they shall be given a pre-paint treatment to provide excellent adhesion of the finish system to the steel and to aid in the prevention of corrosion. Physical and chemical cleaning of the steel shall be accomplished by washing with an alkaline cleaner, followed by a spray treatment with a metallic phosphate solution to provide a uniform fine-grained crystalline phosphate

surface that shall provide both an excellent Bond for the finish and enhance the protection provided by the finish against humidity and corrosive chemicals.

After the phosphate treatment, the steel shall be dried and all steel surfaces shall be coated with a corrosion-resistant finish with Powder Coating process. Surfaces to be coated include the inside of cabinet doors and drawer heads, behind all cross rails, all inside surfaces underneath the cabinet interior bottom panel, inside front and rear posts, inside of sub-base members, and behind adjustable shelf front and back edges. Baking at elevated temperatures to provide maximum properties of corrosion and wear resistance shall then cure the coating. Finishes specified to be a color shall then receive an additional sprayed and heat cured color coat, of the color specified, on all surfaces exposed to view after installation except as follows: drawer bodies, case channels, removable backs in cupboards and removable shelves (other than those in open front units or glazed units with swinging or sliding doors). These parts, along with the area under the toe space enclosure and the back of the cabinet when not exposed to view after installation, shall be #61 Light Neutral.

All CRCA steel parts should be de-greased Zinc plated and coated with zinc phosphate (Coating Thickness should be at least 4.5 grams/mtr<sup>2</sup>) in a multi - tank hot phosphating system. and epoxy powder coated for better corrosion resistance. The thickness of powder coat shall not be less than 50 microns, conforming to relevant BIS code, which accordingly passes the test of Salt Spray for 1000 hours and having the scratch hardness of 3 kgs.

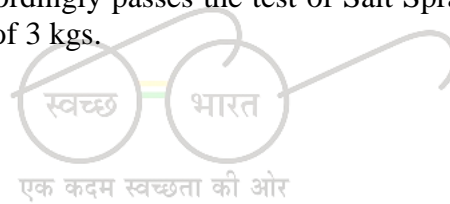

# Particular Specification

## 1.0 Laboratory Furniture

### 1.1 Minimum Steel Thickness of Components of Laboratory Furniture

Sides, top, bottom, back, Shelves, drawers, end cover panels	0.80 mm
Shutters, drawer fronts, stiffeners	1.00 mm
Hinge plates, shelf brackets	1.60 mm
Pedestal structure members, service panel under bench	2.50 mm
Pedestal frame of ERW Tube	1.25 mm
Service panel over bench	1.00 mm
Shelf and Hat Channel- Stiffners	1.25mm

1.2 The laboratory furniture required should be modular in design, made of mainly CRCA Steel in panel form to get the best and full coverage of powder coating and in CKD (Completely Knocked Down) construction so can be erected at site as per approved layout. The furniture should be designed as to maintain height 900mm for standing posture and 750mm for sitting posture.

1.3 The construction should be modular and shall permit reconfiguration for optimal adaptability to meet future change in the layout. The module shall be structurally independent without help of the mechanical fastening of flooring, walls or ceiling. It shall be easy to assemble and reconfigure using simple tooling. The design should allow independent access to the utilities installed, Plumbing lines, electrical panel & instrumentation panel. It should be removable without removing other panels. Each cabinet should be self standing type having individual base frame except the wall Cabinets. Skid, shelf & Hat channel stiffener: 18 G thick G.I. Sheet.

### 1.4 Under Bench Storage Modules: -

All sides of modules should be collapsible and have provision for connecting to the adjacent module with the help of threaded steel screws (finished in nickel chrome plating) end cover panels of end modules on a bench run. The drawer and shutter fronts should be provided with polyethylene gaskets for dust resistance and noise free closing. The shutters should be fixed on the modules with detachable concealed hinges having adjustability in three directions, which is openable to 95° and are self closing on return. The drawer suspension should be of fabricated section and must be spot-welded to drawers. The suspension guides have nylon / plastic bearing rollers for smooth running of fully loaded drawers and incorporate self closing action. The under bench storage modules will be of approved design and can be in combination of shutters with shelf, pull out drawers, shutter with glass. Each door to have minimum 5.0 thick toughened glass and 80 mm wide GI Frame on all 4 sides made out of 18G thick G.I. Sheet, duly epoxy powder coated.

### 1.5 Pedestal Frame

The pedestal frame should be made of high quality ERW steel tubes of size 30mm x 30mm x 1.00mm. Pedestal should be finished in approved colour with epoxy polyester powder paint. Leveling screws will be provided at the bottom of the tubular legs and the same should be covered by means of black plastic spats for good aesthetics.

### 1.6 Bench Top/ Sink Top:

The tabletops shall be of 18 mm Granite of even surface fixed on bench with 12.00mm thick Marine Ply backing or 10.00mm thick neoprene mat as per directions of engineer in charge. The granite shall be fixed to ply with approved adhesive.

### 2.0 Reagent Shelves

Reagent Shelves to be of complete modular design consisting of horizontal 2 stage shelves. The end vertical support should be 0.9mm & horizontal surface shelves of 0.8 mm thick CRCA Sheet surface to be PP Laminated 1 mm thick of approved shade 6mm thick neoprene mat. Each shelf should have load carrying capacity of 30 Kgs. of UDL for the length of 1000 mm. Each vertical panel shall be assembled with horizontal shelf with M6 fasteners having Zinc-Cobalt coating for better corrosion resistance. The reagent shelf should be fixed to the granite top with M6 fasteners. The reagent shelves should have provision of raceway on both sides for electrical points including provision for cutouts.की ओर

### 3.0 Overhead Storage Cabinets

Wall mounted Storage Cabinets should be of complete modular design Consisting of Cabinet Frame, metal/ glass shutters, shelves and SS handles. Cabinet frame should be of 0.8 mm CRCA sheet, with horizontal stiffeners of 1.2mm thick. Metal Shutters are of 0.8mm thick CRCA sheet with profile insert to provide rigidity to the doors. CRCA adjustable shelves should have a load carrying of 40 kg UDL. SS 304 Recess Handles to provide extra corrosion resistance. Hinges have to be spring loaded with CED coating with self closing mechanism. Flush design with no protruding handles for better safety of the users to be provided. Each unit should have a locking facility with 180°, cam lock mechanism .

### 4.0 Electrical Fittings:

Each electrical module consists of

- 1). 16 Amp 5 Pin Socket
- 2). 16 Amp Switch with LED
- 3). Tiny Trip SP 32 Amp (protection device optional and chargeable)

All the above accessories shall have a high temperature withstanding capacity and excellent electrical insulation properties. The rear portion of above accessories, which is in contact with live metal shall be made from thermo set material, which does not melt on heating.

## **5.0 Sink Unit**

The sink unit consisting of a base cabinet, Stainless Steel/ PP Sink, a three way faucet, a peg board and a eye washer.

- 5.1 Base Cabinet : The raw material used for cabinet shall be minimum 0.90 mm thick CRCA MS sheet as per approved design matching with the laboratory furniture. (work benches).
- 5.2 Sink : Sinks shall be of stainless steel of SS 304 grade with over all size of 535mm x 460mm x 215mm. The sink/drip cup shall have waste coupling of 1<sup>1</sup>/<sub>4</sub> “ BSP threads for further connection of waste line plumbing
- 5.3 Water Faucet : Sink unit shall have 3 way (2 Straight + 1 Swan Neck) water tap made up of Brass and with Epoxy powder coatings.

## **6.1 FUME HOOD:**

- Fume Hoods Must be type tested at Manufacturers works as per guide lines of **ASHRAE-110 AM**. Furnish a certificate for the same alongwith the certificate for NIH and EPA standards
- It should be aerodynamically designed for performing better to achieve **face velocity of 4 LPM/0.05 PPM** at front fascia.
- **Over All Dimension:**
  - Sash Opening Vertical : 700 mm
  - Height of wortop from floor : 920-930 mm
  - Clearance when Sash UP : 2400-2550 mm

Minimum overall Size of Fume Hood in mm for 4 ft fume hood:

- 1200 mm Width x 850 mm Depth x 2250 mm Height
- Internal Size of Fume Hood 990 mm length/width
- Worktop:- 990 mm length

## **Material of Construction:**

Rugged construction as per manufacturer design which provides superior protection to both operator and facility in event of mishappening. Material of Construction is CRCA 1.2 mm to 2.0mm thick (cold rolled, close annealed) meeting requirements of ASTM A366.

#### **Interior :**

All 3 interior walls of the fume hood are to be **made from 1.2mm thick CRCA sheet** with **minimum 100 microm** Poly propylene coating for superior chemical, corrosion resistance and **fire retardancy**.

Lower & front vertical facia to be made from 1.2 mm thick CRCA sheet to ensure smooth even flow of air into the hood. The vertical facias may contain the required service controls, electrical fittings and receptacles.

The exterior enclosure side panels of the superstructure shall be constructed of CRCA Sheet 1.2mm thick. Panels shall be removable for access into the interior housing.

Access shall also be gained through removable panels in the interior liner. These interior removable panels of the same material as the liner and will be gasketed with mechanical fasteners and held in place by non-metallic access clips.

#### **6.2 Airfoil**

Ergonomic Aero dynamic curved type lower Air Foil Fixed 1.6 mm Thk SS304 grade well protected for spillage with suitable covering ,aerodynamic design for high performance, low flow & reducing turbulence. creating an air flow to sweep the work surface to remove fumes and sweep them into the baffles.

#### **6.3 Baffle**

Three point suction design of baffle system provides safe ,efficient removal of fumes, when the superstructure is connected ventilation system/blower coated with polypropylene for superior chemical,corrosion resistance and **fire retardancy**.

#### **6.4 Duct Collar**

The rectangular duct collar provide superior baffle efficiency and also reduces noise

#### **6.5 Lighting :**

Fitted with rapid start, vapour sealed LED light at the top with glass sealing. Each fixture shall include LED light to provide adequate light to the work surface. Light fixtures are isolated from the hood interior by tempered glass panel sealed from the hood cavity.

#### **6.6 Fume Hood Sash**

Fume hoods shall have a full view, vertical rising toughened glass sash 6 mm thick fitted in powder coated Aluminium extrusion for smooth and light sash operation. Clear sash open height is 700mm

**Counter balance system:** Single weight, sprocket and chain, counter balance system which prevents sash tilting and permits ease of operation at any point along full width pull. Maximum 3.2 Kg pull required to raise or lower sash throughout its full length of



operating sash opening. Life cycle test sash and weight. Open and close sash against rubber bumper stops.

Constant exhaust Vol at 0.5 m/Sec +/- 20%. Average face velocity when vertical sash is opened at 455 normal height.

### 6.7 Fume Hood service fixtures and fittings

1. **Valves:** Remoted controlled by in and out facility with flexible hose passing through the side / bottom panel of the hood. Color coded washers at hose nozzle outlets and valves mounted inside the fume hood and controlled from the exterior with color coded index handles.

The RHS vertical facia to accommodate remote valves and spout/nozzle fixed on side with copper tubing for following.

- a) Raw water with Duplon PVC flexible 8 mm pipe 25 kg/m<sup>2</sup> alongwith 90 degree PP spout on fume hood side above drip cup.
- b) 3 nos. valves on front facia with 3 nos. 45 degree nozzle/spout on fume hood side connectd with SS pipe 200 mm dia for gases etc..
- c) One no. 200 mm dia drip cup of poly propylene oval / circular shape with bottom coupling with flexible drain pipe 1m.
- d) One no valve and spout for **Chilled** water in and out.

All services to be terminated at the **rear end** for connection to main.

2. **Electrical services:** Single Phase 50 Hz, receptacles rated at 230 V A.C. at 6/16 Amp provided as standard. Electrical fittings on LHS front facia as under:
  - a) LED light on-off rocker switch
  - b) 3 nos.6/16 amp socket and switch-single phase
  - c) 1 NO– NC push buttons with element

Internal wiring of fumehood suitable for single phase 20 amp current to be terminated at rearend for connection to mains alogwith suitable adaptor.

**6.8 Fume Hood Work Surface** – 18 mm thick jet black granite fixed on 12 mm thick ply.

### 6.9 Fume Hood Base

Fume Hood upper units is kept on Base cabinets. It's super structure is coated with PP coating for superior chemical,corrosion resitance and fire retardancy.

Front Shutter / panel of cabinets are with epoxy **powder coated (minimum 70 micron thick)** to match with casework colour in laboratory **and interior to be coated with poly propylene (minimum 100 micron thick)**. **Base cabinet shall be minimum (high) 890mm x 570mm (deep) made form 1.2mm thick CRCA sheet with one shelf, four shutters and partition.**

### 6.10 Fume hood finish :

- All Steel Components are to be epoxy polyester powder coated **minimum 100 micron thick** to give a better and more uniform surface finish with high degree of impact, scratch and corrosion resistance.
- The whole process observed as per the complete **guideline of ISO** / equivalent standards at various required stages.
- The steel surface should be pre treated with Online Jet Type process pre-treatment to ensure thorough cleaning & effective surface preparation to enable excellent bonding during powder coating
- The premium epoxy polyester powder paint of appropriate colour should be applied by automatic means like **automatic robotic electrostatic spray gun** to ensure consistent thickness & excellent surface finish
- The components / material should be moved through the baking oven.
- Suitable temperature (approximately 200 °C) maintained uniformly, throughout the oven and cured for requisite time as per **international standards** recommended by the epoxy powder manufacturer.

## Ducting

1. 3mm PP (i.e. PPGL) with one side smooth & glossy finish and other end is mat finish. The smooth surface should be the inner surface of the duct. On mat side, FRP 3 layer lining to be provided. 25mm x 25 mm Stitch welding is done on inner surface and continuous welding on outer surface with 5 mm welding thickness.
2. FRP lining to be done on the outer surface of PPGL i.e. on mat side with isothelic resin. One layer FRP is one mm. the final layer should be with fine mat to have smooth and good finish. While making the lining, there should not be any air pockets or any sort of Uneven finish.
3. The flange thickness should be 1.5 times of the duct thickness upto 750 mm and 2 times above 750 mm ducting.
4. All flanges are to be matched with M8, GI fasteners and flat washers on both the sides. All the flanges should have fasteners at the 4 corners. All the fasteners to be fixed at a pitch distance of between 125 mm to 150 mm. All the flanges should be properly ground and dressed. Duct support distance should not be more than 2500 mm. Any duct length should not be more than 3600 mm. All square/rectangular ducts with more than 1800 mm length should have a brazing frame at the center on the external surface. Provide 40x40 flanges up to 750 mm duct size and 50x50 above 750 mm. The finish paint should be admiral grey.

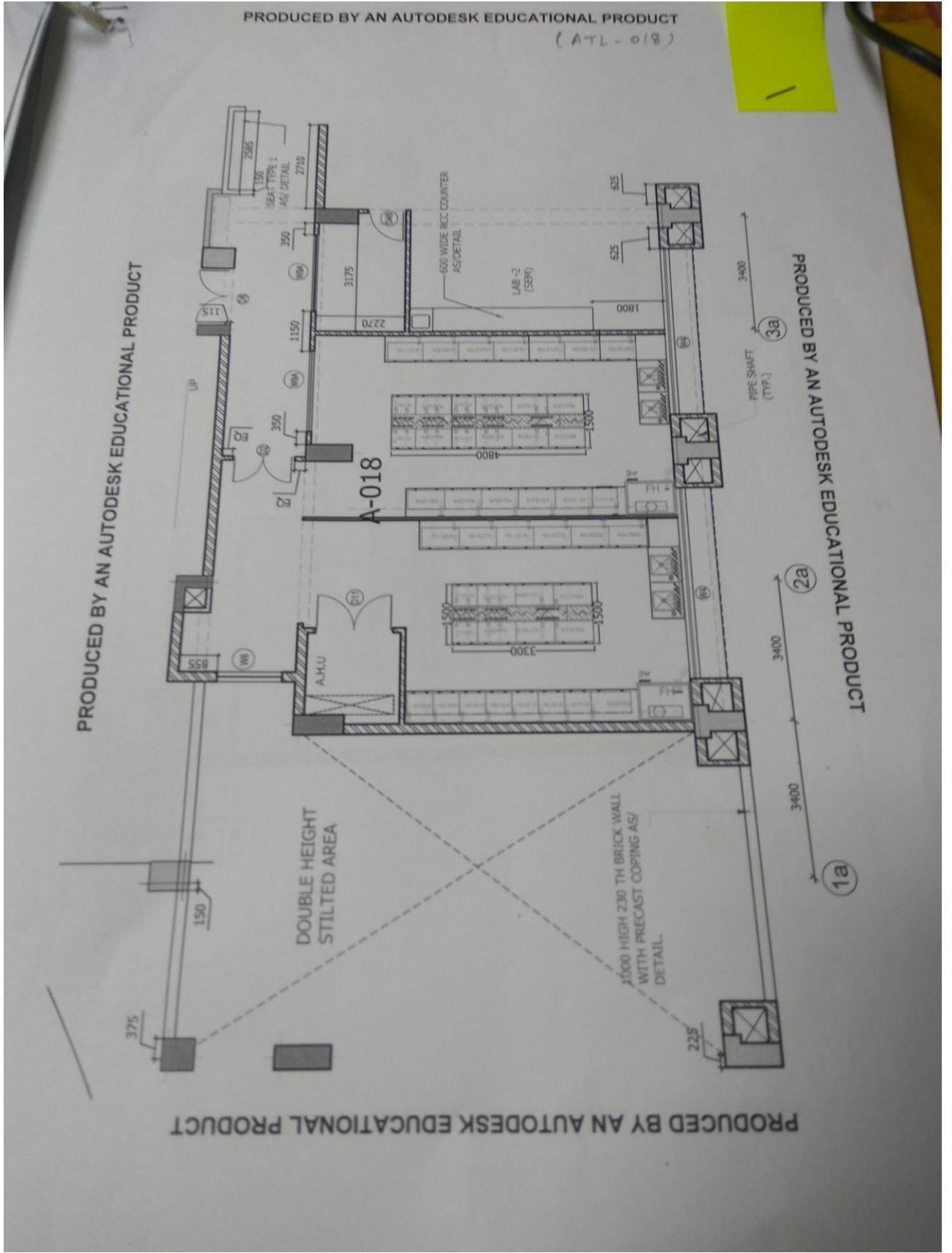

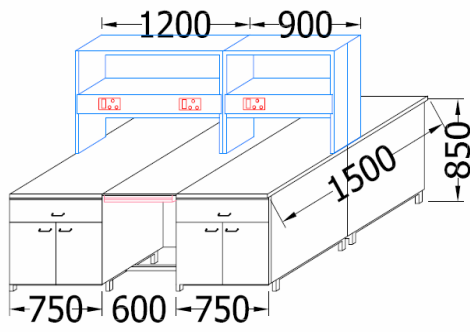

VIEW OF ISLAND BENCH [IB]

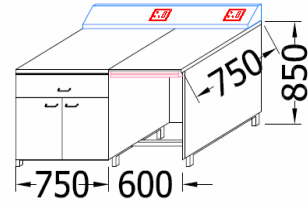
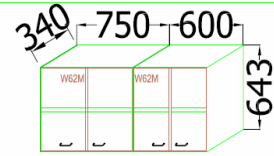

VIEW OF WALL BENCH [WB]

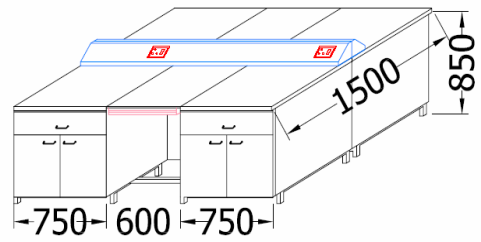

VIEW OF ISLAND BENCH [IB]

एक कदम स्वच्छता की ओर

# Volume II

## Schedule of Quantities



## Schedule of Quantities

Name of Work: A/A GGSIP University, Dwarka Campus, New Delhi

Sub Head: Setting up research lab

S.No	Description	Unit	Qty.	Rate (in Rs.)	Amount (in Rs.)
1	Providing and fixing 750 to 900mm high laboratory work bench with 18mm thick mirror polished granite top with nosing duly fixed on 12mm thick ply or 10 mm thick neoprene mat with adhesive. The ply should be fixed on base cabinet with SS screws/nut bolts. The base cabinet shall consist of pedestal frame and storage unit in modular construction with addon units in C,L,U or any other shape/configuration as per lab requirement. The pedestal frame and storage unit shall be made from CRC sheet as per particular specifications. Each storage unit will consists of a drawer unit, openable shutter and shelf including SS/PP handles, mortice lock, SS hinges, brackets or wheels or other required hardware as per approved design, drawing and specifications and directions of engineer in charge. Area of granite top shall be measured for payment. Granite and ply shall be paid for separately.	Sq. Mtr.	20		
2	Providing and fixing 750 to 900mm high laboratory work bench sink unit with 18mm thick mirror polished granite top with nosing duly fixed on 12mm thick ply or 10 mm thick neoprene mat with adhesive. The ply should be fixed on base cabinet with SS Screws/nut bolts. The base cabinet shall consist of pedestal frame duly covered from three sides in modular construction with addon units in C,L,U or any other shape/configuration as per lab requirement. The pedestal frame and cover shall be made from CRC sheet as per particular specifications. Each sink unit will consist of a pedestal frame with granite top,three side covering and front shutter with provision for fixing of SS Sink of appoved size, water supply and drainage as per approved design, drawing and specifications and directions of engineer in charge. Area of granite top shall be measured for payment. Granite and ply shall be paid for separately.	Sq. Mtr.	2		

3	Providing and fixing Stainless Steel A ISi 304 (18/8) kitchen sink as per IS: 13983 with C.I. brackets and stainless steel plug 40 mm, including painting of fittings and brackets, cutting and making good the walls wherever required. Kitchen sink without drain board. 610x510 mm bowl depth 200 mm	Each	4		
4	Providing and fixing 3 way CP brass swan neck faucet of approved quality conforming to IS:8931. 15 mm nominal bore	Each	4		
5	Providing and fixing of Double Sided two tier Reagent shelf in main and add on configuration of size 1500mm x 300mm x 680mm each with cutouts for electrical module plates, switches, sockets etc. complete as per approved drawing, design, specifications & directions of Engineer in Charge.	mtr	7		
6	Providing and installation of 18mm thick Granite Work top with edge moulding and grooves over 12mm thick backing ply complete as per approved drawing, design, specifications & directions of Engineer in Charge.	Sq. Mtr.	22		
7	Extra for providing opening of required size & shape for wash basins/kitchen sink in kitchen platform, vanity counters and similar location in marble/Granite/stone work including necessary holes for pillar taps etc. including rubbing and polishing of cut edges etc. complete.	each	4		
8	Providing and Fixing Single sided bench mounted electrical trunking of Length 1500mm with cutouts for module plate, switches, sockets etc. on Work Benches complete as per approved drawing, design, specifications & directions of Engineer in Charge.	mtr	10		

9	<p>Providing and fixing partition upto ceiling height consisting of G.I. frame and required board, including providing and fixing of frame work made of special section power pressed/ roll form G.I. sheet with zinc coating of 120 gms/sqm(both side inclusive), consisting of floor and ceiling channel 50mm wide having equal flanges of 32 mm and 0.50 mm thick, fixed to the floor and ceiling at the spacing of 610 mm centre to centre with dash fastener of 12.5 mm dia meter 50 mm length or suitable anchor fastener or metal screws with nylon plugs and the studs 48 mm wide having one flange of 34 mm and other flange 36 mm and 0.50 mm thick fixed vertically within flanges of floor and ceiling channel and placed at a spacing of 610 mm centre to centre by 6 mm dia bolts and nuts, including fixing of studs along both ends of partition fixed flush to wall with suitable anchor fastener or metal screws with nylon plugs at spacing of 450 mm centre to centre, and fixing of boards to both side of frame work by 25 mm long dry wall screws on studs, floor and ceiling channels at the spacing of 300 mm centre to centre.</p>				
	<p>The boards are to be fixed to the frame work with joints staggered to avoid through cracks, M.S. fixing channel of 99 mm width (0.9 mm thick having two flanges of 9.5 mm each) to be provided at the horizontal joints of two boards, fixed to the studs using metal to metal flat head screws, including jointing and finishing to a flush finish with recommended jointing compound, jointing tape, angle beads at corners (25 mm x 25 mm x 0.5 mm), joint finisher and two coats of primer suitable for board as per manufacture's specification and direction of engineer in charge all complete. 66mm overall thickness partition using 8mm thick double skin multipurpose cement board reinforced with cellulose fibre manufactured through autoclaving process (High pressure steam cured) as per IS : 14862 with suitable fibrecement screws.</p>	Sq. Mtr.	32		
10	<p>Providing and fixing G.I. pipes complete with G.I. fittings and clamps, including cutting and making good the walls etc. Internal work - Exposed on wall.</p>				
	a) 15 mm dia. nominal bore	mtr	10		



11	Making connection of G.I. distribution branch with G.I. main of following sizes by providing and fixing tee, including cutting and threading the pipe etc. complete.				
	a) 25 to 40 mm nominal bore	each	2		
12	Painting G.I. pipes and fittings with synthetic enamel white paint over a ready mixed priming coat, both of approved quality for new work.				
	a) 15 mm diameter pipe.	mtr	10		
13	Providing and fixing C.P. brass angle valve for basin mixer and geyser points of approved quality conforming to IS:8931				
	a) 15 mm nominal bore.	Each	6		
14	Providing and fixing G.I. Union in existing G.I. pipe line, cutting and threading the pipe and making long screws including excavation, refilling the earth or cutting of wall and making good the same complete wherever required.				
	a) 50 mm nominal bore.	Each	4		
15	Providing and fixing on wall face unplasticised - Rigid PVC rain water pipes conforming to IS: 13592 Type A including jointing with seal ring conforming to IS:5382 leaving 10 mm gap for thermal expansion. (i) Single socketed pipes				
	a) 75 mm diameter	mtr	10		
16	Providing and fixing on wall face unplasticised - PVC moulded fittings / accessories for unplasticised - PVC rain water pipes conforming to IS:13592 Type A including jointing with seal ring conforming to IS : 5382 leaving 10 mm gap for thermal expansion.				
	a) Shoe (Plain)				
	i) 75 mm Shoe	Each	2		

17	Providing and fixing on wall face unplasticised - PVC moulded fittings / accessories for unplasticised - PVC rain water pipes conforming to IS:13592 Type A including jointing with seal ring conforming to IS : 5382 leaving 10 mm gap for thermal expansion.				
	a) Bend 87.5 degree				
	i) 75 mm bend	Each	4		
18	Providing and fixing unplasticised-PVC pipe clips of approved design to unplasticised-PVC rain water pipes by means of 50x50x50 mm hard wood plugs, screwed with M.S. screws of required length including cutting brick work and fixing in cement mortar 1:4 ( 1 cement : 4 coarse sand ) and making good the wall etc. complete.				
	a) 75 mm	Each	4		
19	Distempering with 1st quality acrylic distemper (ready mixed) of approved manufacturer, of required shade and colour complete, as per manufacturer's specification. Two or more coats on new work	Sqm	100		
20	Applying one coat of water thinnable cement primer of approved brand and manufacture on wall surface. Water thinnable cement primer	Sqm	100		
21	Supplying and drawing following sizes of FRLS PVC insulated copper conductor, single core cable in the existing surface/ recessed steel/ PVC conduit as required.				
a)	3 x 4 sq. mm	Metre	40.00		
b)	6 x 4 sq. mm	Metre	60.00		
c)	9 x 4 sq. mm	Metre	80.00		
22	Supplying and fixing of following sizes of steel conduit along with accessories in surface/recess including painting in case of surface conduit, or cutting the wall and making good the same in case of recessed conduit as required.				
a)	25 mm	Metre	25.00		
b)	32 mm	Metre	35.00		

23	Supplying and fixing following modular switch/ socket on the existing modular plate & switch box including connections but excluding modular plate etc. as required.				
a)	5/6 amps switch	Each	50.00		
b)	15/16 amp switch	Each	25.00		
c)	3 pin 5/6 amp socket outlet	Each	50.00		
d)	6 pin 15/16 amp socket outlet	Each	25.00		
24	Supplying and fixing following Modular base & cover plate on existing modular metal boxes etc. as required.				
a)	3 Module	Each	25.00		
b)	6 Module	Each	25.00		
25	S/F the following accessories for commercial Dado Trunking etc. as required.				
	a) Internal coupler moulded NET1050	Each	4.00		
	b) End cap moulded NEP 1050	Each	4.00		
26	Supplying & Fixing the following module boxes in th existing commercial Dado Trunking of size 100mm (H) x 50mm (D) etc. as required.				
	a) 3 module box NSB1T3I	Each	12.00		
	b) 8 module box NSB8I	Each	12.00		
27	Supplying & Fixing of commercial Dado Trunking NCT/1050 of ove rall dimensions 100 mm x 50 mm on the surface of wall etc. as required.	Metre	12.00		
28	Supplying and fixing the following ms flexible pipe complete with accessories etc. as required.				
	25mm size	Meter	10.00		
	32 mm size	Meter	10.00		
29	Supplying and fixing 63 amps rating, 240/415 volts, "C" curve, miniature circuit breaker suitable for inductive load of following poles in the existing MCB DB complete with connections, testing and commissioning etc. as required				
	a) Tripple pole and neutral	Each	1.00		

30	Providing and installation of Fume Hood of 4 feet auto bypass bench type having Superstructure MS electrogalvanised & Powder coated outer casing. Vertical Type Sash with toughened glass Granite worktop with Oval/circle Shaped 230x78x135mm PP cupsink. Remotely operated color coded services with SS braided flexible hose & brass fittings. A soft touch button panel with main switch, switch for blower & tube light & spare switch is provided. LED indicators to show the ON & OFF positions of switches are provided. and (230V, 6/16A, 50Hz) electrical sockets & switches of approved make as per particular specifications and as per directions of Engineer-in-Charge.	Each	1		
31	Supplying and Installation of Centrifugal Blower for fume hoods PP + FRP lined Blower with FRP-vinylester impeller and a motor, 1400RPM, 3H.P. KEC/CGL or equivalent Make Motor, 100mm W.G. (ACLB 550)	Each	1		
32	Providing and fixing ducting for fumehood / spot extractor made up of 3 mm poly propylene and 3mm Fibre reinforce plastic including flexible bend, flange, rigid bend, pipe etc. connectin to fumehood and blower and fixing on wall / ceiling surface with brackets as required at site and as per directions of engineer in charge.	Sq. Mtr.	17		
<b>Total</b>					



**EE/UWD**