



Guru Gobind Singh Indraprastha University

Sector 16C, Dwarka, New Delhi -110075

Website: <http://ipu.ac.in>

(PURCHASE BRANCH)

Phone No. 011-25302149

011-25302150

27th December, 2011

GGSIPU/Kitchen Equipment/Purchase/2011-12/183

To,

NOTICE INVITING QUOTATION

You are requested to submit your offer in **sealed cover** for the Supply & Installation of Utensils and Kitchen equipment for Hostel Mess (Boys & Girls) in the University.

Name of Work	Supply & Installation of Utensils and Kitchen Equipment for Hostel Mess (Boys & Girls)
Last Date, Time and Venue for submission of tender	Latest by 11 th January, 2012 (Wednesday) at 02:30 P.M. in the office of Addl. Dy. Registrar (Purchase), Library Block, GGSIP University, Sector 16C, Dwarka, New Delhi - 110075
Earnest Money Deposit (EMD)	Rs. 70,000/- (Seventy Thousand Rupees) in the form of DD in favour of Registrar, GGSIPU, Payable at Delhi
Opening of offers in presence of the authorized representatives of bidders, if any.	11.01.2012 (Wednesday) at 03.00 PM

This enquiry has also been posted on **University website**. Please **super scribe the sealed envelope containing quotation with reference no. of the quotation and quotation for Utensils and Kitchen Equipment. Detailed Specifications and quantity are as follows:**

A. Firms who fulfill the following requirements shall be eligible to apply:

Eligibility Criteria for Technical Bid

1.	Letter of Transmittal	Annexure – A
2.	Declaration by Bidder	Annexure – B
3.	Compliance to Bid Requirement	Annexure – C
4.	Organizational Structure: - Legal status of the company/ organization with legal proof along with copies of the original documents	Annexure – D
	Income Tax Registration (PAN No.), Service Tax Registration, Vat Registration/ TIN Number	Attach copies of the original documents
5.	Average financial turnover of Rs. 50 Lacs during the immediate last three consecutive financial years, duly audited, signed & stamped by a Chartered Accountant.	Annexure E
6.	The bidder should not have incurred losses in more than one year in the last 3 consecutive financial years, duly certified by Chartered Accountant, along with copies of audited profit and loss account of last three years	

7.	Warranty should be 12 months (on site and comprehensive) for all items from the date of satisfactory installation.	Attach Warranty Certificate
8.	An affidavit on Rs. 100/- (non-judicial stamp paper) declaring that the bidder/ organization has not been blacklisted/debarred by any of the government/ public sector agency in the last 3 years. A declaration of fair business practice by the Bidder.	Annexure – F
9.	Firm should have executed atleast one of the following in the last five year *One single order of similar work of Supply & Installation of Utensils and Kitchen Equipment having value of Rs. 15 Lakhs OR Two similar work of Supply & Installation of Utensils and Kitchen Equipment having value of Rs. 10 Lakhs each OR Three similar work of Supply & Installation of Utensils and Kitchen Equipment having value of Rs. 7 Lakhs each Explanation: 1. “Similar work” means the work of Supply & Installation of Utensils and Kitchen Equipment in public sector undertaking, Govt. Department, Educational Institutions or in reputed private sector. 2. “Value” shall mean gross value of the completed work including the cost of materials. This should be certified by an officer of the client organization on their letter-head.	Annexure - G
10.	Tenderer should also have the authorization of full support of maintenance and spares as detailed in this tender document from Manufacturer.	Attach copies of the original documents
11.	The Manufacturer/Authorized Dealer should have a authorized service centre in Delhi NCR only	Attach copy of proof
12.	Joint ventures shall not be accepted.	

B. Submission of bid in 2 (two) envelop system:-

Envelope –1:- Which consists of ‘**Technical Bid**’–‘Separate Envelope’

Envelope –2:- Which consists of **Financial/Commercial Bid**–‘Separate Envelope’

Documents for eligibility condition: TECHNICAL BID

C.

(Necessary enclosures for **Envelope-1**, which consists of Technical Bid):

The technical bid should be in the following format. (Annexure A to G)

- 1. Name and address of the bidder**
- 2. Telephone No., Mobile number and Fax number and Email address**
- 3. Status of the firm**
 - i) An proprietary firm**
 - ii) Partner ship firm**
 - iii) Limited company or corporation**



- 4. Particulars of registration with various govt. offices/bodies**
- 5. PAN number with a copy of the latest return**
- 6. TIN/Sales tax number with a copy of the latest return**
- 7. Service tax number, if any with a copy of the latest return**
- 8. Address of the manufacturing Unit/plants with telephone numbers, mobile numbers, fax numbers and email address.**
- 9. Earnest money deposit as prescribed against each item in the form of DD/FD in favour of Registrar, GGSIPU payable at Delhi.**
- 10. The copy of the terms and conditions as given in the tender with the signature and seal of the Agency/Distributor/proprietor/manufacturer.**
- 11. The Certificate of sole Distributor/Agency or Manufacturer indicating the person is Manufacturer, Agency or Distributor.**
- 12. Should have minimum average annual financial turn over of Rs. 50 Lacs during the last three years ending March 2011 duly certified by Chartered Accountant as per Annexure E.**
- 13. A certificate from the Agency/Distributor/Manufacturer certifying the guarantee/warranty period on the equipments and the spares.**
- 14. The firm should provide a list of users with their contact details, including phone/email.**
- 15. AMC for 36 Months after one year warranty should be clearly mentioned including replacement of spare parts.**
- 16. The technical specification along with the literature (if any) of the equipment without mentioning any cost should be given in the format given below. If any add on items other than the specifications mentioned in the tender may also be mentioned separately.**

Signature and seal of the authorized signatory.

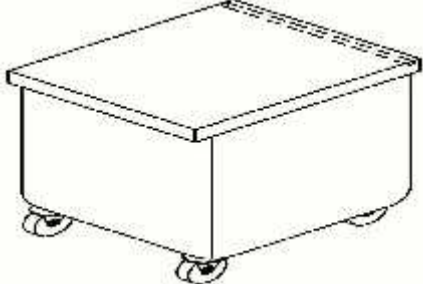
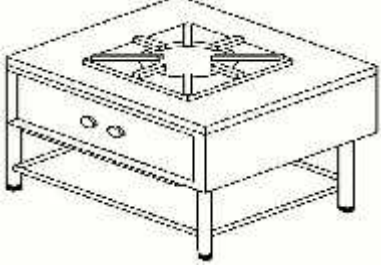
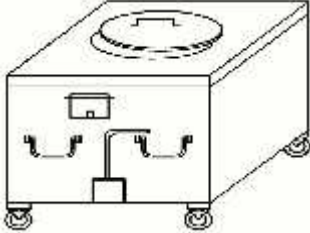

D. **Envelope –2:-** Which consists of duly filled **Financial/Commercial Bid** – ‘Separate Envelope’. No cutting and overwriting condition shall be permitted.

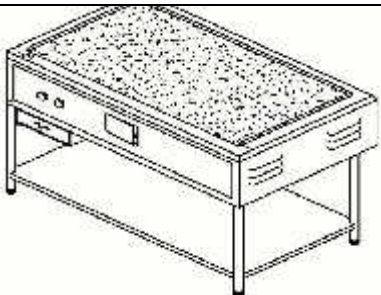
The detailed specifications of Utensils and Kitchen equipment requirement as under:

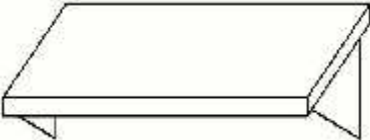
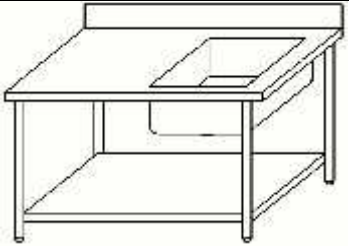
S.No.	Name of Equipments with Specification	Dimension	Photo	Qty	Unit Cost In Rs.	Amount in Rs. (inclusive taxes)
1.	Atta / Maida Bin with Lid on Wheels: The entire bin made of 18 swg ss sheet on tiny caster wheels & with top opening lid.	400 x 600 x 750		1		
2.	Single Burner Range: Structure made of mild steel angle frame duly rust proof painted, top of 16 swg ss sheet, front panel and udershelf 18 swg ss sheet, vertical legs of ss round pipe of 16 swg, 1.5” diameter with nylon adjustable feet. The top will have 1 nos. of burners with individual needle control valve.	600 X 600 X 850		2		
3.	Tandoor: Top constructed of 16 swg, and side covering of 20 swg ss sheet, wheels heavy duty 4” Dia.	750 x 750 x 850		1		

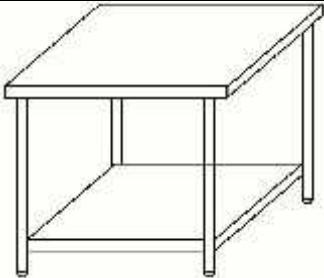
S.No.	Name of Equipments with Specification	Dimension	Photo	Qty	Unit Cost In Rs.	Amount in Rs. (inclusive taxes)
4.	<p>Dosa Plate: Structure made of mild steel angle frame duly rust proof painted. Top of 14 mm mild steel plate, front panel and undershelf 18 swg ss sheet, vertical legs of ss round pipe of 16 swg, 1.5" diameter with nylon adjustable feet. Complete with c.i perforated grill, heavy -duty high pressure rv burners' pilot, individual control valves.</p>	900 X 750 X 850		1		
5.	<p>Wet Grinder: Body: made of 16swg ss: 304 sheet food gr. Complete with revolving drum, grinding stone & wooden scrapper.Motor: 1 h.p. Electric motor & gear box.</p>	10 LITRS		1		
6.	<p>Wall Shelf: Shelf constructed from ss: 304 of 18 swg Pre-polish sheet & supports constructed from ss: 304 of 14 swg sheet.</p>	900 X 300		1		
7.	<p>Work Table with Sink: Structures made of mild steel angle, duly rust proof painted, top and sink of 16 swg. And under shelf of 18 swg. ss sheet, Vertical of ss round pipe of 16 swg . The table will mounted on nylon adjustable feet.</p>	1500 X 600 X 850 + 150		1		

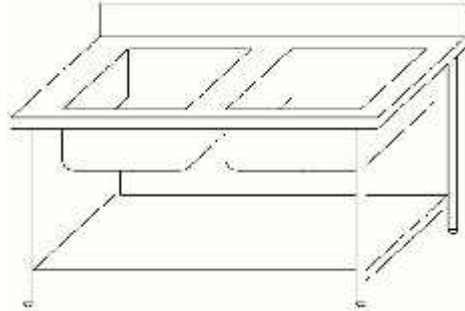
S.No.	Name of Equipments with Specification	Dimension	Photo	Qty	Unit Cost In Rs.	Amount in Rs. (inclusive taxes)
8.	4 Door Refer Imported	1250 x 800 x 2100		2		
9.	Glass Rack	1200 X 300		1		
10.	Milk Boiler: Body: double walled fully constructed from ss:304 Sheet complete with water level indicator & temperature Controller etc.	40 LITRS		1		
11.	Vegetable Cutter with 6 Nos. Blades	Standard Make		1		
12.	Work Table: Structure made of mild steel angle (38x38x5mm) frame duly rust proof painted, top of 16 swg ss sheet. Vertical legs of ss round pipe of 16 swg.1.5" diameter with nylon adjustable feet.	1200 X 600 X 850		1		

S.No.	Name of Equipments with Specification	Dimension	Photo	Qty	Unit Cost In Rs.	Amount in Rs. (inclusive taxes)
13.	Water Boiler: Body: double walled fully constructed from ss:304 Sheet complete with water level indicator & temperature Controller etc.	100 LITRS		1		
14.	Two Sink Unit: Entire sink unit of 16 swg ss sheet on ss tubular legs with adjustable bullet feet. Provided with cross bracing & back splash.	1200 X 675 X 850 + 150		1		
15.	Tea / Coffee Dispenser: Double walled glass wool insulated all s.s. Sheet body.Fitted with 3.0 kw heating element with auto temp.controller & indicating lamp, water level indicator, Gun metal faucet one for water and another for milk.	30 LITRS		1		

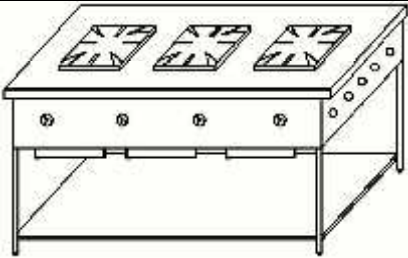
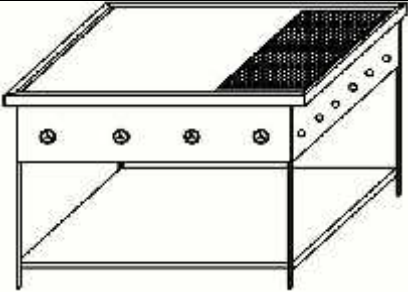
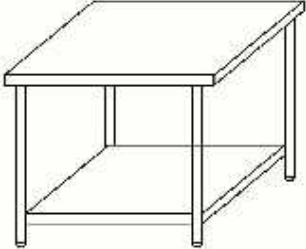
S.No.	Name of Equipments with Specification	Dimension	Photo	Qty	Unit Cost In Rs.	Amount in Rs. (inclusive taxes)
16.	Three Burner Indian Cooking Range: Structure made of mild steel angle frame duly rust proof painted, top of 16 swg ss sheet, front panel and udershelf 18 swg ss sheet, vertical legs of ss round pipe of 16 swg, 1.5" diameter with nylon adjustable feet. The top will have 3 nos. of burners with individual needle control valve.	1800 X 600 X 750		1		
17.	Chapati Plate Cum Puffer: Structure made of mild steel angle frame duly rust proof painted. Top of 12 mm mild steel, front Panel and udershelf 18 swg ss sheet, vertical legs of ss round pipe of 16 swg, 1.5" diameter with nylon adjustable feet. Complete with CI perforated grill for puffing of chapattis, heavy -duty high pressure RV burners pilot, individual control valves Indian oil corporation approved	1200 X 750 X 850		1		
18.	Chapati Rolling Table: Structure made of mild steel angle (38x38x5mm) frame duly rust proof painted, top of 16 swg ss sheet. Vertical legs of ss round pipe of 16 swg.1.5" diameter with nylon adjustable feet.	1200 X 750 X 850		1		
19.	Conveyor Toaster			1		

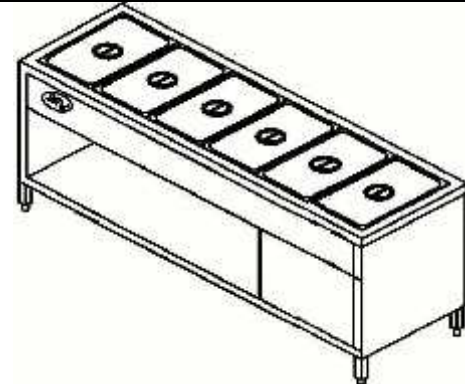
S.No.	Name of Equipments with Specification	Dimension	Photo	Qty	Unit Cost In Rs.	Amount in Rs. (inclusive taxes)
20.	<p>Pulverizer: This ss pulverizer is best suited to grind dry/wet masala i.e. chilly, spices, sugar, herbs, paste & chuteny etc. Runs easily & saves time. This dry/wet grinder are made of stainless steel body. 24 hours running capacity. Works without any noise. Economic in operation, easy to maintain. Attractive in finish. Special air colling system for motor.</p>	2 HP		1		
21.	Dough / Spiral Mixer	80 LITRS		1		
22.	<p>Hot & Normal Bain Marie: Structure made of mild steel angle duly rust proof painted, top made of 18 swg food grade ss sheet 304. Inner tank made of 18 swg ss 304 sheets, outer body 20 swg ss sheet, with 3 kw. Immersion type heating element with auto temp. controller & indicating lamp also provided. Insulation puf type glass wool.</p>	2100 X 675 X 850		2		
23.	Tray Slide	2100 X 675		2		

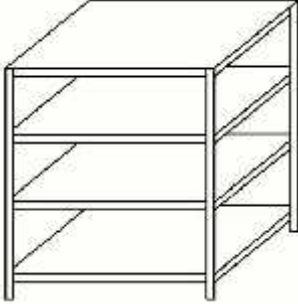
S.No.	Name of Equipments with Specification	Dimension	Photo	Qty	Unit Cost In Rs.	Amount in Rs. (inclusive taxes)
24.	<p>Storage Rack: The heavy duty 4 tier shelf are made of 18 swg ss sheet on 4 nos. uprights on adjustable bullet feet for uneven floor.</p>	900 X 450 X 1800		1		
Total Amount in Rs. (inclusive taxes)						

Net rates are Rs. _____, in words (_____)

Date and time of opening of **Envelope No. 2** i.e. Financial Bid shall be intimated after evaluation the Technical Bids of Eligible Agencies/Bidders.

LETTER OF TRANSMITTAL

From:

To

The Registrar
GGS IPU
Sector 16C, Dwarka,
Delhi

Sub: Submission of Tender Document for the work of “**Supply & Installation of Utensils and Kitchen Equipment for Hostel Mess (Boys & Girls)**”.

Sir,

Having examined the details given in Tender document for the above work, I/we hereby submit the relevant information:-

1. I/we hereby certify that all the statement made and information supplied in the enclosed annexures / forms accompanying statement are true and correct.
2. I/we have furnished all information and details necessary for eligibility and have no further pertinent information to Supply & Installation.
3. I/we also authorize the GGSIPU to approach individuals, employers, firms and corporation to verify our competence and general reputation.

Name & Signature(s) of Bidder(s) with seal

DECLARATION BY THE BIDDER

We _____ (Name of the Bidder) hereby represent that we have gone through and understood the Bidding Document (which in two parts) in Part-I (Commercial Section & Technical Section) and Part-II (Schedule of Quantities) and that our Bid has been prepared accordingly in compliance with the requirement stipulated in the said documents.

We are submitting a copy of Bidding Document marked “Original” as part of our Bid duly signed and stamped on each page in token of our acceptance. We undertake that Part-I and Part-II of the Bidding Document shall be deemed to form part of our bid and in the event of award of work to us, the same shall be considered for constitution of Contract Agreement. Further, we shall sign and stamp each page of this Part-I and Part-II as a token of Acceptance and as a part of the Contract in the event of award of Contract to us.

We further confirm that we have indicated prices in Schedule of Quantities and submitted in Price Bid in separately sealed envelope. We confirm that rate quoted by us includes price for all works/activities/supply etc. as mentioned in item description of the items in Schedule of Quantities.

SIGNATURE OF BIDDER : _____

NAME OF BIDDER : _____

COMPANY SEAL : _____

Note : This declaration should be signed by the Bidder’s representative who is signing the Bid.

COMPLIANCE TO BID REQUIREMENT

We hereby agree to fully comply with, abide by and accept without variation, deviation or reservation all technical, commercial and other conditions whatsoever of the Bidding Documents and Addendum to the Bidding Documents, if any, for subject work issued by GGSIPU.

We hereby further confirm that any terms and conditions if mentioned in our bid (Un-priced as well as Priced Part) shall not be recognized and shall be treated as null and void.

SIGNATURE OF BIDDER : _____
NAME OF BIDDER : _____
COMPANY SEAL : _____

ORGANISATION STRUCTURE

1. Name & Address of the Bidder :
2. Telephone No./Fax No./ e-mail :
3. Legal status of the Bidder (attach copies of original document defining the legal status)
 - a) An Individual
 - b) A proprietary firm
 - c) A firm in partnership
 - d) A limited company or Corporation
 - e) A Public Sector Undertaking
4. Particulars of registration with various Government Bodies (Attach attested Photo Copy)
Organization /Place of registration Registration No
5. PAN No. -----
6. Names and Titles of Directors & Officers with designation to be concerned with this work. :
7. Name & Designation of individuals authorized to act for the organization :
(Pl attach power of attorney in favour of authorized representative duly signed by authorized signatory)
8. Was the Bidder ever required to suspend work for a period of more than six months continuously after you commenced the construction? If so, give the name of the project and reasons of suspension of work. :
9. Has the Bidder, or any constituent partner in case of partnership firm, ever abandoned the awarded work before its completion? If so, give name of the project and reasons for abandonment. :
10. Has the Bidder, or any constituent partner in case of partnership firm, ever been debarred/ black listed for tendering in any organization at any time? If so, give details. :
11. Has the Bidder, or any constituent partner in case of partnership firm, ever been convicted by a court of law? If so, give details. :
13. Any other information considered necessary but not included above. :

(Stamp, Name & Signature of Bidder)

DETAILS OF ANNUAL TURNOVER

FINANCIAL DETAILS

Financial Years	Gross Annual Turnover on Supply & Installation of Utensils and Kitchen equipment for Hostel Mess (Boys & Girls) (In Lakhs)	Profit/Loss (In Lakhs)
2010-2011		
2009-2010		
2008-2009		

Audited balance sheet and profit & loss account for above three years to be submitted.

(Stamp, Name & Signature of Bidder)

DECLARATION FOR FAIR BUSINESS BY THE BIDDER

(Affidavit on Non-Judicial Stamp Paper of Rs.10/- duly attested by Notary / Magistrate)

This is to certify that We, M/s _____ in submission of this offer confirm that:-

- i) We have not made any misleading or false representation in the forms, statements and attachments in proof of the qualification requirements;
- ii) We do not have records of poor performance such as abandoning the work, not properly completing the contract, inordinate delays in completion, litigation history or financial failures etc.
- iii) Business has not been banned with us by any Central / State Government Department/ Public Sector Undertaking or Enterprise of Central / State Government.
- iv) We have submitted all the supporting documents and furnished the relevant details as per prescribed format.
- v) The information and documents submitted with the tender by us are correct and we are fully responsible for the correctness of the information and documents submitted by us.
- vi) We understood that in case of any statement/information/document furnished by us or to be furnished by us in connection with this offer is found to be incorrect or false, our EMD in full will be forfeited and business dealings will be banned.
- vii) We have not been punished / penalized by way of imprisonment in last three years.
- viii) We have not been blacklisted/debarred by any of the Government/Public Sector Agency in last three years.
- ix) We have no personal dealing with any of the employees of the University.

SEAL, SIGNATURE & NAME OF THE BIDDER

Signing this document

DETAILS OF SIMILAR WORKS COMPLETED DURING LAST 05 (FIVE) YEARS

Sl.No.	DESCRIPTION OF WORK	POSTAL ADDRESS OF CLIENT WITH CONTACT NUMBERS	CONTRACT VALUE	COMPLETED VALUE	STARTING DATE	SCHEDULED COMPLETION DATE	ACTUAL COMPLETION DATE	REASONS FOR DELAY, IF, ANY

(Stamp & Signature of Bidder)

Terms and conditions.

1. Sealed tenders super scribed with the name of the equipments addressed to Addl. Dy. Registrar (Purchase), Library Block, GGS Indraprastha University, sector 16 C Dwarka, New Delhi 110075.
2. The vendor/supplier should be a registered firm, should possess PAN, TIN (VAT)/Sales tax and service tax as applicable.
3. The firm should have a minimum average turnover of Rs. 50 lakhs during the last three years ending on March 2011 duly certified by **Chartered Accountant as per Annexure E**
4. The firm should have ideally supplied the equipment being quoted elsewhere and should provide a list of users with their contact details, including phone/email.
5. The tender will follow a simultaneous two bid system. One the technical bid and the other financial bid (where there will be only the cost of the equipment, the cost of spares and cost of add on items will be quoted.). The final cost should be very clear and there should not any hidden cost i.e. there should not be any ambiguity in the total cost. The financial bid will be sealed in a separate cover, super scribed “**FINANCIAL BID**” and will be inserted in the big sealed cover along with the technical bid and EMD.
6. The EMD (refundable) should be in the form of demand draft/FD in favour of the Registrar, GGSIPU payable at Delhi.
7. The rate quoted should be FOR, in Indian Rupees, should be inclusive of all taxes and the rates should be shown separately. The rates should be quoted legibly in figure as well as in words. There should not be any cutting, overwriting or erasing in the rates or specifications. If there is any difference in the rates of words and figure in a tender the figure written in words will considered as final. The rates should be strictly in accordance with the actual specifications met by the item. Some basics accessories that are essential for the ability of the equipment to meet all the specifications should be included in the basic price (with breakup, if appropriate), and any other accessories may be quoted separately.
8. The specifications must provide full details as declared by the manufacturer, preferable enclosing manufacturer’s brochure/catalog/literature. Specifications of the equipments which are less than the stipulated ones in the tender will not be considered.
9. A compliance/deviation statement for all specifications mentioned here must be provided with each quotation.
10. The tender should mention the life of the equipment, the availability of spares, the local technical support, after sales service, the cost involved in the AMC and Comprehensive AMC, free services etc. if any.
11. A letter of authority from the original manufacturer for sale and service of the equipment.
12. The tender may be rejected in full or any part at the discretion of the university.
13. An affidavit on non judicial stamp paper worth Rs. 100/- stating that (1) the firm has not been debarred/blacklisted by any university/autonomous organization/ govt./semi govt. organizations.,(2)will observe fair dealing in the business and that this equipment has not been sold for less than the price quoted, (3) has no personal dealing with any of the employees of this university. (Annexure F)

14. No Advance will be given.
15. The payment will be made after supply and satisfactory installation of the equipment.
16. The successful bidder who has not completed the requirement of BG within the stipulated time the EMD will be forfeited and likely to be debarred from further participation in any bid in the university.
17. The firm will facilitate the inspection team to visit the premises as and when required by the committee. However, the expenses will be met by the purchasing organization.

Validity

18. The rates should be valid for at least six months from the date of opening of the tender.

Warranty/Guarantee

19. On site warranty and guarantee of the equipment should one year after installation.
20. The successful bidders will have to submit a performance guarantee of 10% of the quoted price in the form of FD/BG which should have a validity of three months beyond the warranty/guarantee within ten days from the day of confirmation of the tender.

Time period & supply

21. The equipment should be supplied within four weeks for indigenous and eight weeks for imported goods.
22. Variation in the quantity of work order will be up to 30% from the proposed quantity and must be acceptable to the bidder for a period of one year from the date of acceptance of the work order.

Penalty

23. The equipment is to be supplied on the stipulated time frame. A penalty of 0.5% of the purchase order will be charged for the delay per week or a part thereof. The penalty will be charged to a maximum of 5% of the supply order. The same is also applicable for not supplying the equipment in good condition as stipulated in the purchase order as per specification.
24. In case of the supply of defective/damaged equipments, the firm will remove the same and replace it with brand new equipment with the said specification in good working condition at the cost of the firm/supplier. No extra cost to this effect will be born by this university. No rectification or repair will be permitted during the time of installation.
25. The penalty will be deducted from the bill, and if, the equipment is not supplied as per the specification, the penalty will be recovered from the EMD/performance security/other payment pending in the university.
26. In case of non supply/defective supply the university may also take strict action like debar or blacklist the firm from participation any tender process in this university.

Rejection of the tender.

27. The bid without bid security (EMD) will summararily be rejected.
28. The bid without the documents required as mentioned in the technical bid are likely to be rejected.
29. Late tender(s) will not be accepted.
30. No separate covers other than the consolidated sealed cover for tender will be accepted.
31. The terms and conditions other than the stipulated in the above tender will not be considered. The conditional tenders are likely to be rejected.
32. The tender may be rejected in full or any part at the discretion of the university.

Legal

33. All the disputes are subjects to the jurisdiction of Delhi only.

[Pankaj Agrawal]
Addl. Dy. Registrar [Purchase]